



DOMINATOR SERIES FINNED COPPER GAS BOILERS (MODEL DB) & WATER HEATERS (MODEL DW) INSTALLATION & OPERATION MANUAL



DESIGNED AND TESTED ACCORDING TO A.S.M.E. BOILER AND PRESSURE VESSEL CODE, SECTION IV FOR A MAXIMUM ALLOWABLE WORKING PRESSURE OF 160 PSI, 1103 kPa WATER.

WARNING: If the information in this manual is not followed exactly, a fire or explosion may result causing property damage, personal injury or loss of life.

Do not store or use gasoline or other flammable vapors and liquids in the vicinity of this or any other appliance.

WHAT TO DO IF YOU SMELL GAS:

- Do not try to light any appliance.
- Do not touch any electrical switch. Do not use any phone in your building.
- Immediately call your gas supplier from a neighbor's phone. Follow the gas supplier's instructions.
- If you cannot reach your gas supplier, call the fire department.

Installation and service must be performed by a qualified installer, service agency or the gas supplier.

WARNING: Failure to properly vent this unit can cause excessive amounts of carbon monoxide resulting in severe personal injury or death!

INSTALLER, THESE INSTRUCTIONS TO BE AFFIXED ADJACENT TO THE UNIT.
CONSUMER, RETAIN THESE INSTRUCTIONS FOR FUTURE REFERENCE PURPOSES.



260 North Elm Street
Westfield, MA 01085
Phone: (413) 568-9571
Fax: (413) 568-9613

7555 Tranmere Drive
Mississauga, Ontario L5S 1L4 Canada
Phone: (905) 670-5888
Fax: (905) 670-5782



AVERTISSEMENT. Assurez-vous de bien suivre les instructions données dans cette notice pour réduire au minimum le risque d'incendie ou d'explosion ou pour éviter tout dommage matériel, toute blessure ou la mort

Ne pas entreposer ni utiliser d'essence ou ni d'autres vapeurs ou liquides inflammables à proximité de cet appareil ou de tout autre appareil.

QUE FAIRE SI VOUS SENTEZ UNE ODEUR DE GAZ:

- **Ne pas tenter d'allumer d'appareil.**
- **Ne touchez à aucun interrupteur; ne pas vous servir des téléphones se trouvant dans le bâtiment.**
- **Appelez immédiatement votre fournisseur de gaz depuis un voisin. Suivez les intructions du fournisseur.**
- **Si vous ne pouvez rejoindre le fournisseur, appelez le service des incendies.**

L'installation et l'entretien doivent être assurés par un installateur ou un service d'entretien qualifié ou par le fournisseur de gaz.

CONTENTS

Before Your Start	page 2
Ratings & Capacities	page 3
Boiler/Water Heater Location	page 3
Combustion Air & Ventilation	page 3
General Venting Guidelines	page 9
Venting Options	page 9
Vertical/Chimney Venting	page 10
Outdoor Venting	page 11
Common Vent Systems	page 12
General Piping Requirements	page 13
Heating System Piping	page 15
Domestic Water Supply Piping	page 18
Gas Supply Piping	page 22
Electrical Wiring	page 23
General Operation	page 23
Boiler/Water Heater Operation	page 24
Operating Instructions	page 28
Checking & Adjustments	page 30
Control Description	page 31
Maintenance	page 34
Trouble-Shooting	page 37
Repair Parts.....	page 39
Start Up Form.....	page 47

BEFORE YOU START

This manual covers the application, installation, operation and maintenance of a Dominator Series finned copper heating boiler/water heater/pool heater.

To obtain the safe, dependable, efficient operation and long life for which this heating boiler/water heater was designed, these instructions must be read, understood and followed.

The Dominator Series finned copper heating boiler/water heaters have been design certified by CSA for use with natural and propane gas under the latest revision of ANSI-Z21.10.3/CSA 4.3, Gas Water Heaters, and ANSI-Z21.13/CSA 4.9, Gas-Fired Low Pressure Steam and Hot Water Boilers and CAN 1-3.1 Industrial and Commercial Gas Fired Packaged Boilers. Each unit has been constructed and hydrostatically tested for a maximum working pressure of **160 psi, 1103 kPa** in accordance with Section IV of the A.S.M.E. Boiler and Pressure Vessel Code.

All aspects of the boiler/water heater installation must conform to the requirements of the authority having jurisdiction, or, in the absence of such requirements, to the National Fuel Gas Code, ANSI Z223.1/NFPA 54-latest revision. Where required by the authority having jurisdiction, the installation must conform to the Standard for Controls and Safety Devices for Automatically Fired Boilers, ANSI/ASME CSD-1.

In Canada, the installation must be in accordance with the requirements of CSA B149.1 or .2, Installation Code for Gas Burning Appliances and Equipment.

If installed in the Commonwealth of Massachusetts, you **MUST FOLLOW** the additional instructions contained in the back of this manual, MACODE-3.

The owner should maintain a record of all service work performed with the date and a description of the work done. Include the name of the service organization for future reference.

Direct all questions to your RBI distributor or contact the RBI Customer Service Department, 260 North Elm Street, Westfield, MA 01085 for U.S. or 7555 Tranmere Drive, Mississauga ONT L5S 1L4 for Canada. Always include the model and serial numbers from the rating plate of the boiler/water heater in question.

RATINGS & CAPACITIES

Before undertaking the installation of the Dominator Series boiler/water heater check the rating plate to ensure that the unit has been sized properly for the job. The "Net I=B=R Ratings" specify the equivalent amount of direct copper radiation that the unit can supply under normal conditions. Also ensure that the unit has been set up for the type of gas available at the installation site. Other important considerations are the availability of an adequate electrical supply, fresh air for combustion and a suitable chimney or vent system.

BOILER/WATER HEATER LOCATION

1. This boiler/water heater is suitable for indoor and outdoor installations. Locate the boiler/water heater in an area that provides good access to the unit. Servicing may require the removal of jacket panels. Allow the minimum clearances between adjacent construction and the boiler/water heater as listed in Table 1.

NOTE: Service clearances are not mandatory, but are recommended to ensure ease of service should it be required.

Table 1

	Clearance to Combustibles		Service Clearance	
	in	mm	in	mm
Top	6	153	20	508
Back	6	153	24	610
Left Side	6	153	24	610
Right Side	6	153	24	610
Front	6	153	30	762
Flue	6	153		

2. An optimum site will be level, central to the piping system, close to a chimney or outside wall and have adequate fresh air for combustion. Ensure that the boiler/water heater is level from front to back and from side to side. Use metal shims to level the boiler/water heater. Electrical and electronic components must also be protected from exposure to water during operation and maintenance. DO NOT install this boiler/water heater in a location that would subject any of the gas ignition components to direct contact with water or excessive moisture during operation or servicing.
3. Ensure that the floor is structurally sound and will support the weight of the boiler/water heater.

NOTE: The Dominator may be installed directly on combustible flooring, but never on carpeting.

4. Locate the boiler/water heater in an area that will prevent water damage to adjacent construction should a leak occur or during routine maintenance. If such a location doesn't exist, a suitable drain pan that's adequately drained must be installed under the unit.
5. DO NOT place this boiler/water heater in a location that would restrict the introduction of combustion air into the unit or subject the air inlet to a negative pressure, see "GENERAL VENTING GUIDELINES".

WARNING: Never store combustible materials, gasoline or any product containing flammable vapors or liquids in the vicinity of the boiler/water heater. Failure to comply with this warning can result in an explosion or fire causing extensive property damage, severe personal injury or death!

6. NEVER place this boiler/water heater in a location that would subject it to temperatures at or near freezing. See the "Freeze Protection" section on page 13.

CAUTION: Units installed outdoors MUST be protected from ice and snow accumulation or the unit may be damaged voiding the warranty!

COMBUSTION AIR & VENTILATION

WARNING: This boiler/water heater must be supplied with combustion air in accordance with Section 5.3, Air for Combustion & Ventilation, of the latest revision of the National Fuel Gas Code, ANSI Z223.1/NFPA 54 and all applicable local building codes. Canadian installations must comply with CSA B149.1 or .2 Installation Code for Gas Burning Appliances and Equipment, or applicable provisions of the local building codes. Failure to provide adequate combustion air for this boiler/water heater can result in excessive levels of carbon monoxide which can result in severe personal injury or death!

To operate properly and safely this boiler/water heater requires a continuous supply of air for combustion. NEVER store objects on or around the boiler/water heater!

CAUTION: Combustion air contaminated with fluorocarbons or other halogenated compounds such as cleaning solvents and refrigerants will result in the formation of acids in the combustion chamber. These acids will cause premature failure of the boiler/water heater voiding the warranty!

CAUTION: If the boiler/water heater is operated while the building is under construction it MUST be protected from wood, concrete, sheet rock and other types of dust. Failure to properly protect the unit from construction dust will damage the unit voiding the warranty!

Buildings will require the installation of a fresh air duct or other means of providing make-up air if the intake air option isn't used. Any building utilizing other gas burning appliances, a fireplace, wood stove or any type of exhaust fan must be checked for adequate combustion air when all of these devices are in operation at one time. Sizing of an outside air duct must be done to meet the requirements of all such devices.

WARNING: Never operate the Dominator in an environment subjected to a negative pressure unless the air intake is connected to the outdoors. Failure to comply with this warning can result in excessive levels of carbon monoxide causing severe personal injury or death!

All Air From Inside The Building

If the Dominator is to be located in a confined space the minimum clearances listed in Table 1 must be maintained between it and any combustible construction. When installed in a confined space **without the intake air option**, Figures 1, 2 & 3, two permanent openings communicating with an additional room(s) are required. The combined volume of these spaces must have sufficient volume to meet the combustion air requirements of all gas utilization equipment. Fireplaces, wood stoves or any type of exhaust fan must be considered when making this determination. Each opening must have a minimum free area of **1 in²/1000 Btu/hr, 2200 mm²/kW** based on the total input rating of ALL gas utilization equipment in the confined area. Each opening must be no less than **100 in², 64,516 mm²** in size. The upper opening must be within **12 in, 305 mm** of, but not less than **3 in, 76 mm** from, the top of the enclosure. The bottom opening must be within **12 in, 305 mm** of, but not less than **3 in, 76 mm** from, the bottom of the enclosure.

Figure 1 - Vertical Venting with a Metal Chimney System and Inside Air

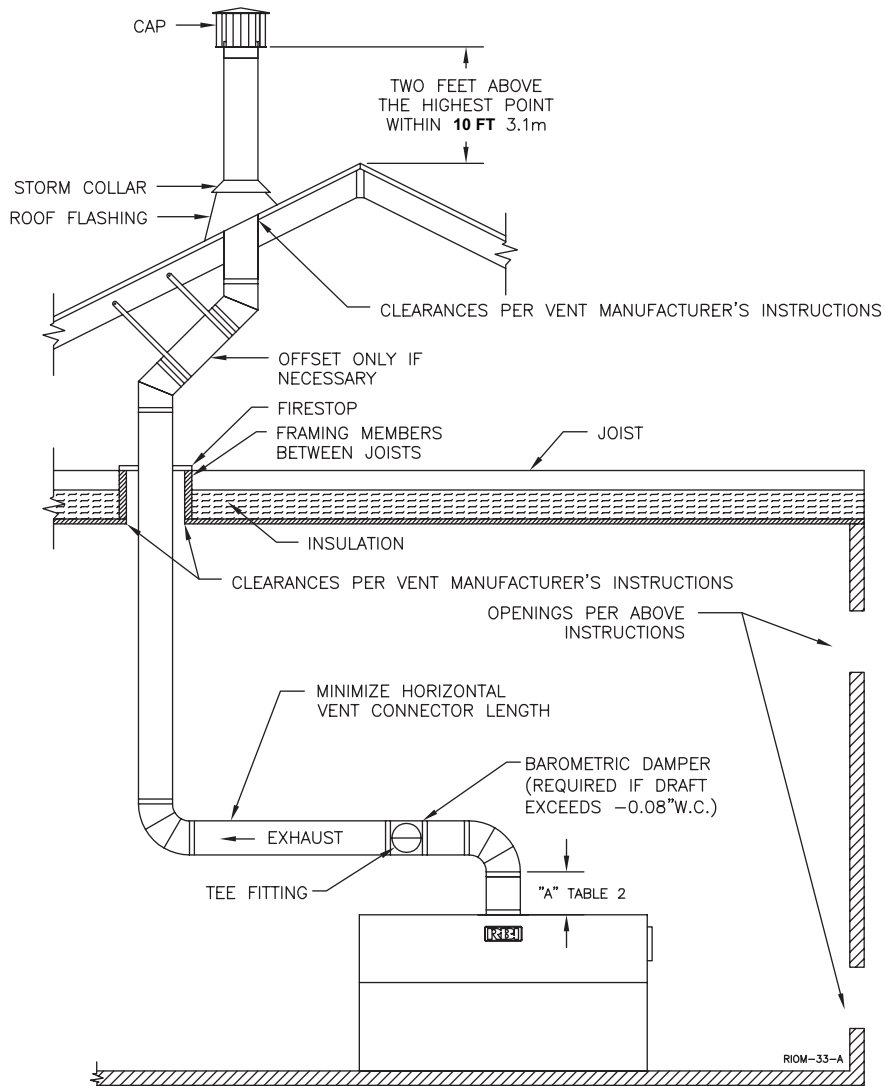

Figure 2 - Vertical Venting using a Masonry Chimney and Inside Air

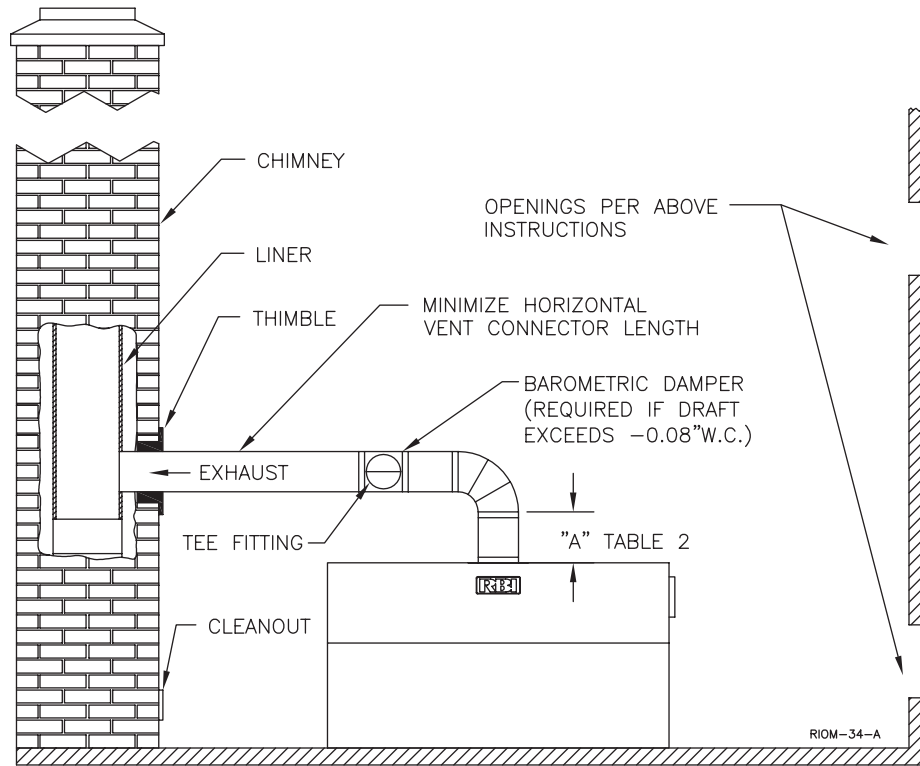

Figure 3 - Horizontal Venting using Inside Air

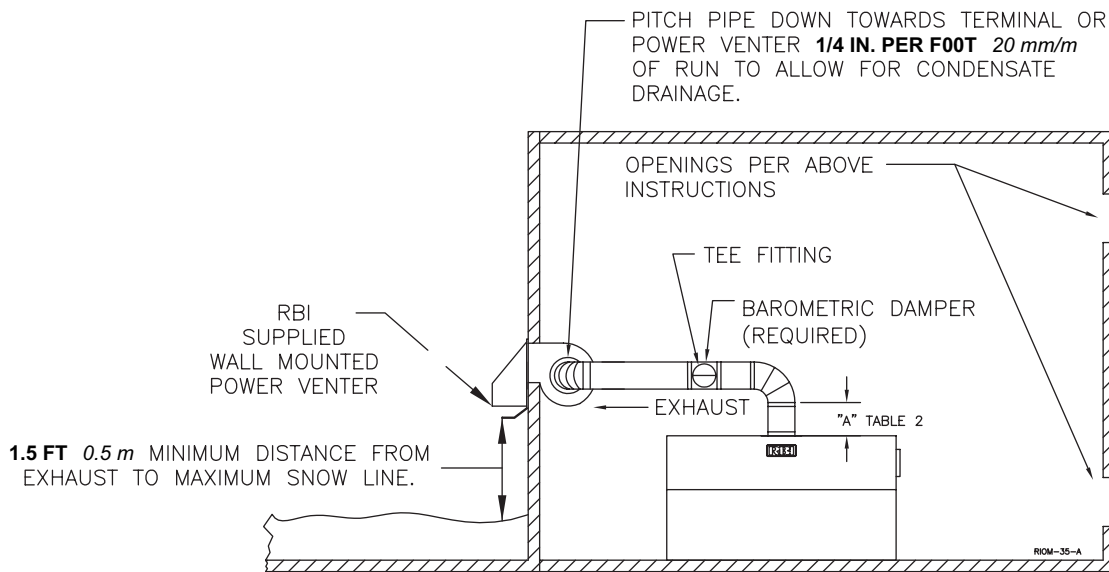

Table 2

VENT PIPE DIAMETER		MINIMUM VERTICAL RISE OFF THE TOP OF UNIT "A"	
IN.	mm	FT	mm
5" TO 10"	127 TO 254	12"	305
12" TO 18"	305 TO 457	24"	610

All Air From Outside The Building

When installed in a confined space **without utilizing the intake air option** two permanent openings communicating directly with, or by ducts to, the outdoors or spaces that freely communicate with the outdoors must be present. The upper opening must be within **12 in, 305 mm** of, but not less than **3 in, 76 mm** from, the top of the enclosure. The bottom opening must be within **12 in, 305 mm** of, but not less than **3 in, 76 mm** from, the bottom of the enclosure.

Where directly communicating with the outdoors or communicating with the outdoors through vertical ducts, each opening shall have a minimum free area of **1 in²/4000 Btu/hr, 550 mm²/kW** of the total input rating of all of the equipment in the enclosure.

Where communicating with the outdoors through horizontal ducts, each opening shall have a minimum free area of **1 in²/2000 Btu/hr, 1100 mm²/kW** of the total input rating of all of the equipment in the enclosure. When ducts are used, they must have the same cross-sectional area as the free area of the opening to which they connect.

When calculating the free area necessary to meet the make-up air requirements of the enclosure, consideration must be given to the blockage effects of louvers, grills and screens. Screens must have a minimum mesh size of **1/4 in, 6.4mm**. If the free area through a louver or grill is not known, ducts should be sized per Table 3.

Table 3 - Make-up Air Louver Sizing

Input (MBH)	Required Cross Sectional Area					
	1/4 in 6.4 mm Wire Screen		75% Free Area Metal Louvers		25% Free Area Wooden Louvers	
	in ²	cm ²	in ²	cm ²	in ²	cm ²
300	75	484	100	645	300	1935
400	100	645	133	860	400	2581
600	150	968	200	1290	600	3871
750	188	1210	250	1613	750	4839
900	225	1452	300	1935	900	5806
1050	263	1694	350	2258	1050	6774
1350	338	2177	450	2903	1350	8710
1500	375	2419	500	3226	1500	9677
1950	488	3145	650	4194	1950	12,581
2100	525	3387	700	4516	2100	13,548

Canadian installations must comply with CSA B149.1 when **air supply** is provided by natural air flow from the outdoors for **natural draft**, partial fan-assisted, fan-assisted, or power draft-assisted **burners**, there shall be a permanent **air supply** opening(s) having a cross-sectional area of not less than **1 in² per 7,000 Btuh (310 mm² per kW)** up to and including **1 million Btuh**, plus **1 in² per 14,000 Btuh (155 mm² per kW)** in excess of **1 million Btuh**.

Intake Air Option - General Guidelines

This configuration provides combustion air directly to the boiler/water heater's air intake using a dedicated pipe to obtain combustion air from the outdoors. Combustion air can be drawn in horizontally through the same outside wall which terminates the exhaust gases or vertically through the roof, see Figures 4, 5, 6 & 7.

WARNING: Common intake air systems may be used provided the common duct is sized properly and an intake combustion air damper is installed in the intake air pipe of each heater. Improper installation can result in excessive levels of carbon monoxide which can cause severe personal injury or death!

Single wall galvanized smoke pipe, single wall aluminum pipe or flexible aluminum pipe can be used for the intake air pipe. It must be sized per Table 4. All joints in metal combustion air systems must be secured using corrosion resistant fasteners and sealed using a suitable Silicone caulk. **The combustion air system MUST be supported by the building structure not the boiler/water heater.**

Table 4 - Intake Air Pipe Sizing

Model Size	Pipe Diameter	
	in	mm
300 & 400	6	152
600 & 750	8	203
900 & 1050	10	254
1350 - 2100	12	305

CAUTION: A stack damper interlocked with the unit should be installed in the intake air pipe when the infiltration of sub-freezing air could occur, otherwise the unit could freeze up voiding the warranty!

Intake Air Option - Horizontal Guidelines

The maximum equivalent length for the horizontal combustion air pipe on installations that used the Direct Vent option is **35 ft, 10.8 m**. The maximum equivalent length for the horizontal combustion air pipe on installations that use the Horizontal Power Vent option is **100 ft, 30.5 m**. Each 90° elbow and the combustion air terminal are equal to **10 linear ft, 3.0 m** of pipe. If horizontal runs exceed **5 ft, 1.5 m** they must be supported at **3 ft, 0.9 m** intervals with overhead hangers. The certified combustion air terminal from RBI must be used and installed as shown in Figures 4 and 5.

Intake Air Option - Vertical Guidelines

The maximum length for the vertical combustion air pipe is **30 ft, 9.1 m** plus two 90° elbows. A listed, nonrestrictive combustion air cap must be used. The combustion air cap must terminate as shown in Figure 6. The penetration point in the roof must be properly flashed and sealed.

Figure 4 - Horizontal Combustion Air and Venting for a Single Unit

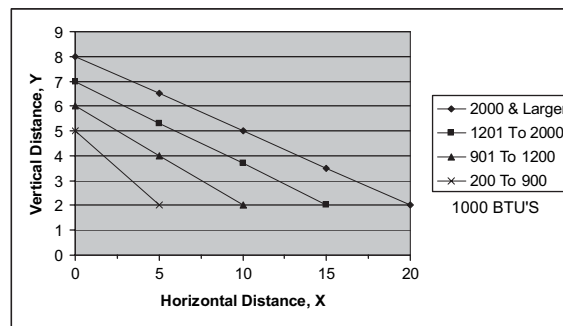
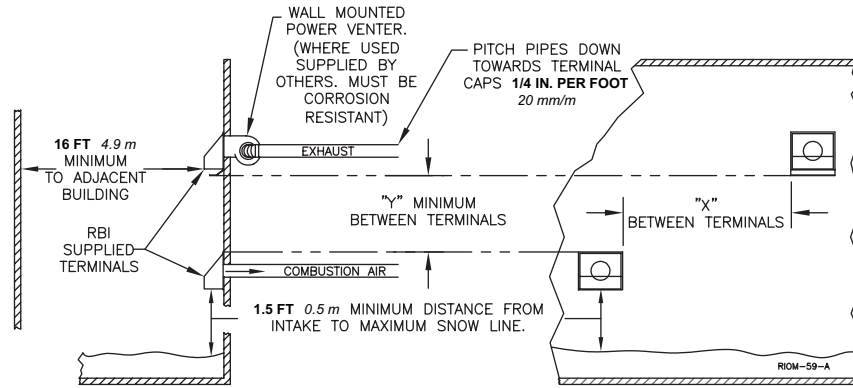

When running horizontal combustion air and venting for single or multiple units, exhaust and combustion air terminals must be installed on the same plane (outside wall) in order to prevent pressure differences due to prevailing winds. In cold climates, double-wall or insulated inlet pipe recommended to prevent condensation.

Figure 5 - Horizontal Combustion Air and Venting for Multiple Units

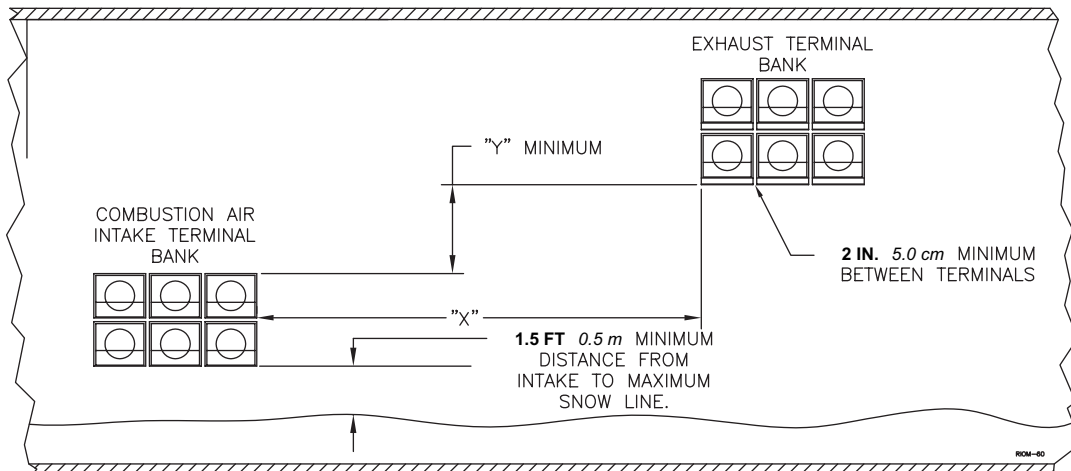
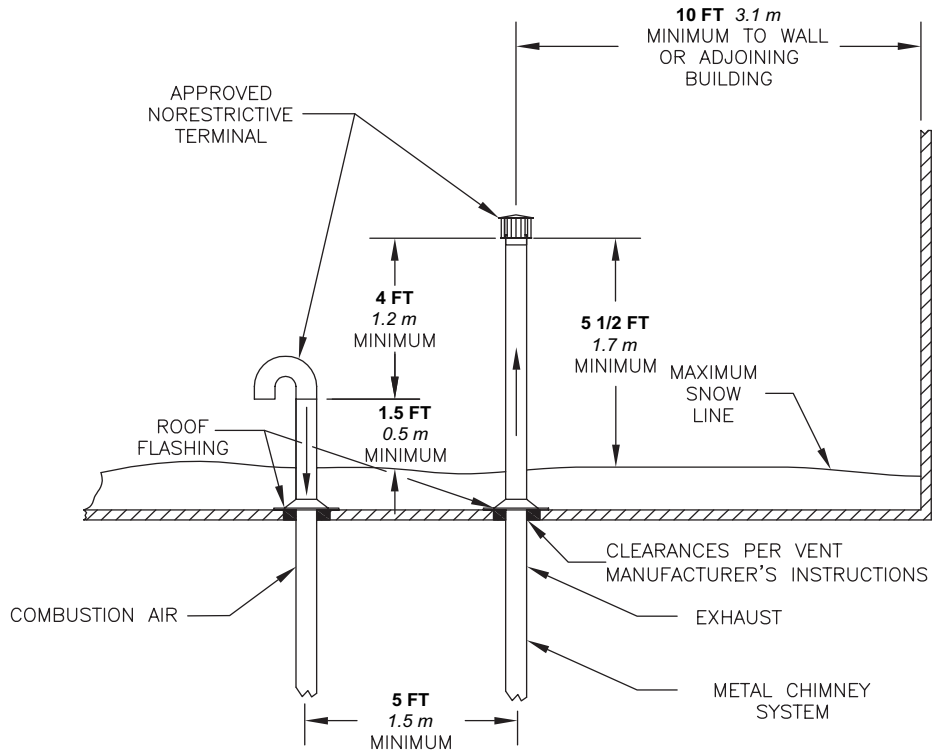

Figure 6 - Vertical Combustion Air and Venting, Metal Chimney System Shown

Locate exhaust terminal downwind from air intake to reduce potential for flue gas recirculation.



RIOM-12

Figure 7 - Combination Air Intake And Venting, Masonry Chimney Shown

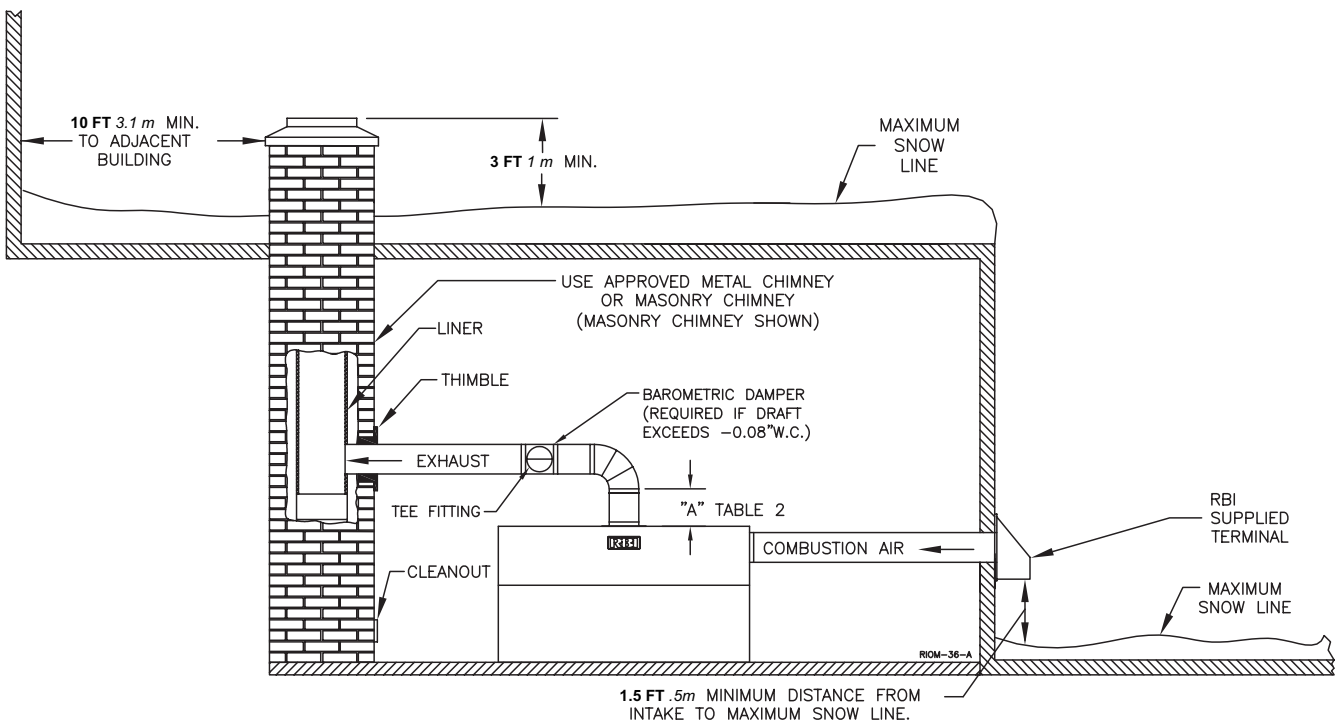

1.5 FT .5m MINIMUM DISTANCE FROM INTAKE TO MAXIMUM SNOW LINE.

GENERAL VENTING GUIDELINES

WARNING: The vent installation must be in accordance with Part 7, Venting of Equipment, of the National Fuel Gas Code, ANSI Z223.1/ NFPA 54-latest revision or applicable provisions of the local building codes. Canadian installations must comply with CSA B149.1 or .2 Installation Code. Improper venting can result in excessive levels of carbon monoxide which can result in severe personal injury or death!

All vent systems must be fully supported by the building structure and not by the boiler/water heater. Appropriate thimbles and fire-stops must be used where required.

WARNING: Common vent systems must be properly engineered and sized to provide a negative draft of .01 to 0.08 in, .25 to 2.0 mm W.C. at the flue outlet! Common positive pressure vent systems are not to be used. Improper installation can result in excessive levels of carbon monoxide which can cause severe personal injury or death!

NOTE: A single acting *barometric damper* must be installed directly to the boiler/water heater flue outlet to ensure proper operation. This does not apply to outdoor units or direct vent positive pressure units.

NOTE: Some venting applications may require the stop to be removed for smooth operation. The barometric damper should be located after the flue collector, refer to Figures 2, 3 and 7 for proper location. Be sure that the damper is mounted horizontally (never vertically). Carefully follow the instructions provided with the barometric damper. Check with local codes for specific requirements.

In Canada, B149 (7.25 Draft Regulators) states the damper shall be of double-acting type.

WARNING: To avoid spillage into the room of dangerous flue gas containing carbon monoxide, the opening in damper must never face against the flow of flue gas.

VENT SYSTEM OPTIONS

The Dominator may be vented the following ways:

1) ***Vertical/Chimney Venting, Negative Pressure, Category I*** - uses an approved metal chimney system or properly lined masonry chimney. Combustion air is obtained from the space in which the unit is installed or from the outdoors. A barometric damper must be installed near the flue outlet when venting vertically. See Figures 6 and 7. This also applies to any fan-assisted chimneys or vents.

2) ***Direct Vent, Positive Pressure, Category III*** - for horizontal vent runs equivalent to **35 ft, 10.7 m** or less. A stainless steel vent system certified to UL 1738 for installations in the United States, ULS636 for installations in Canada must be used when combustion air is ducted from outdoors, from the same wall.

3) ***Horizontal Vent, Negative Pressure, Category I*** - for horizontal vent runs equivalent to more than **35 ft, 10.7 m** (90 degree elbow equals 10 equivalent feet). A dedicated wall mounted power venter and barometric damper must be used. The vent system can be single wall galvanized steel or type B vent pipe. Combustion air is obtained from the space in which the unit is installed or from the outdoors.

A barometric damper must be installed when the horizontal run is longer than 35 equivalent feet. (90 degree elbow = 10 equivalent feet). If this is the case, a power venter must also be used.

If horizontal run is less than 35 equivalent feet, do not use a barometric damper. Follow applicable instructions under the "COMBUSTION AIR & VENTILATION" section.

4) ***Outdoor Installation*** - uses the outdoor option kit. Barometric damper is not required.

NOTE: All venting, combustion air material supplied by installer. All venting material must be approved for the application. Consult the vent manufacturer's product literature.

ANSI Categorization

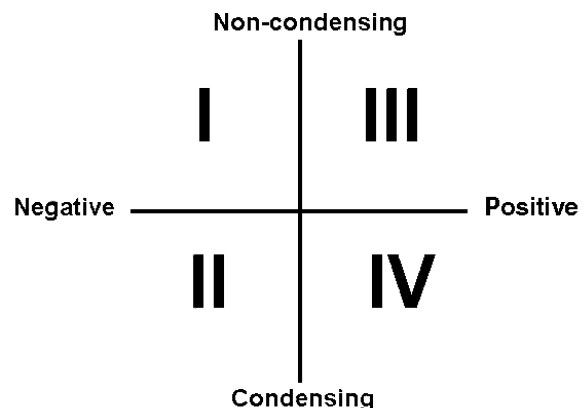

VERTICAL/CHIMNEY VENTING

The Dominator is listed as a Category I appliance when vented vertically into a metal chimney system or properly sized masonry chimney, Figures 1,2, 6 & 7. The chimney must provide a negative pressure of **.01 to 0.08 in**, **.25 to 2.0 mm W.C.** at the boiler/water heater flue collar with the unit running at full load. A barometric damper must be installed between the flue collar and the vent connector. Approved thimbles and fire-stops must be used when combustible construction is penetrated.

WARNING : If an appliance using any type of a mechanical draft system operating under positive pressure is connected to a chimney flue, never connect any other appliances to this flue. Doing so can result in excessive levels of carbon monoxide which can cause severe personal injury or death!

Chimney Inspection & Sizing

A thorough inspection of the masonry chimney must be performed to ensure that the chimney is clean, properly constructed, lined and sized. Exterior masonry chimneys should not be used unless properly lined to prevent condensation and draft problems. Table 5 lists the equivalent breeching and flue sizes required for the boiler/water heater. When more than one appliance is connected to the same chimney flue, the flue must be large enough to safely vent the combined output of all of the appliances.

Table 5 - Equivalent Breeching & Chimney Size

Model Size	Pipe Diameter	
	in	mm
300 - 400	6	152
600	7	178
750	8	203
900 - 1050	10	254
1350	12	305
1500 - 2100	14	356

Note: These sizes are based on a **20 ft, 6.1m** chimney height.

Vent Connections

Locate the boiler/water heater as close to the chimney as possible. Use the shortest, straightest vent connector possible for the installation. If horizontal runs exceed **5 ft, 1.5 m** they must be supported at **3 ft, 0.9 m** intervals with overhead hangers. Use a type B, single wall stainless or single wall galvanized steel vent pipe the same diameter as the flue collar to connect the boiler/water heater to a masonry chimney. When using an approved metal chimney system use the appropriate vent connector. The vent connector should be sloped up toward the chimney at a minimum rate of **1/4 in/ft, 20 mm/m**. On masonry chimneys the connector must terminate flush with the inside of the chimney flue, Figure 2. Fasten each single wall vent connection with at least 3 corrosion resistant sheet metal screws.

WARNING: Never install a vent pipe having a diameter different than that of the boiler/water heater flue collar. Failure to comply with this warning can result in excessive levels of carbon monoxide which can cause severe personal injury or death.

Always provide a minimum clearance of **6 in, 152 mm** between single wall vent pipe and any combustible materials. Type B1 vent may be used, clearance between it and any combustible material must be as listed.

WARNING: Failure to maintain minimum clearances between vent connectors and any combustible material can result in a fire causing extensive property damage, severe personal injury or death!

DIRECT VENT, POSITIVE PRESSURE, CATEGORY III

In this configuration the boiler/water heater blower is used to push the flue products to the outdoors while drawing combustion air from the outdoors. The equivalent length of the vent system **must not** exceed **35 ft, 10.7 m**. The Intake Air Option instructions under the "COMBUSTION AIR & VENTILATION" section must be followed! The vent system must be sized per Table 5.

Horizontal Direct Vent Systems - Figures 4 & 5

The vent materials used in horizontal vent systems must be certified to UL 1738 for installations in the United States, ULS636 for installations in Canada. The certified vent terminal from RBI must also be used.

The maximum equivalent length for the horizontal vent and combustion air pipes is **35 ft, 10.7 m** for each. Each 90° elbow and the vent and intake air terminals are equal to **10 ft, 3.1 m** of straight pipe. To maximize the performance of single wall sheet metal vent systems locate 90° elbows as far from the boiler as possible and from one another. For best results, horizontal vent systems should be as straight as possible.

The vent system must be both gas tight and water tight. All seams and joints in metal pipes must be joined and sealed in accordance with the vent system manufacturer's instructions.

When horizontal vent runs exceed **5 ft, 1.5 m** they must be supported at **3 ft, 0.9 m** intervals with overhead hangers. The vent system must be pitched down, toward the vent terminal, **1/4 in/ft, 21 mm/m**. If any part of a single wall metal vent system passes through an unheated space it must be insulated with insulation rated for **400°F, 204°C**.

Horizontal vent systems shall terminate at least **4 ft, 1.2 m** below, **4 ft, 1.2 m** horizontally from or **1 ft, 0.3 m** above any door, window or gravity air inlet into any building. It must not terminate less than **4 ft, 1.2 m** horizontally from, and in no case above or below, unless a **4 ft, 1.2 m** horizontal distance is maintained, from electric meters, gas meters, regulators and relief equipment and not less than **7 ft, 2.1 m** from any adjacent public walkway. The bottom of the vent terminal(s) shall be located at least **5 ft, 1.5 m** above the air intake terminal(s) unless there is a minimum **5 ft, 1.5 m** horizontal separation between them. Avoid terminal locations likely to be affected by winds, snow drifts, people and pets. Protect building materials and vegetation from degradation caused by the flue gases.

Vertical Direct Vent Systems - See Figure 6

The maximum length for the vertical vent and combustion air pipes is **35 ft, 10.7 m** plus two 90° elbows for each. If any part of a single wall metal vent system passes through an unheated space it must be insulated with insulation rated for **400°F, 204°C**. Structural penetrations must be made using approved fire-stops.

A listed, nonrestrictive vent cap must be used. The top of a vertical vent system must extend at least **5½ ft, 1.7 m** above the roof surface that it passes through, **4 ft, 1.2 m** above the intake air cap, see Figure 6.

HORIZONTAL VENT, NEGATIVE PRESSURE, CATEGORY I

In this configuration a wall-mounted power venter must be used to pull the flue products horizontally from the unit and vent them to the outdoors, see Figures 3, 4 & 5. The air for combustion is taken from the space in which the unit is installed, or from the outdoors. The applicable instructions under the “COMBUSTION AIR & VENTILATION” section must be followed!

To maximize the performance of single wall sheet metal vent systems locate 90° elbows as far from the boiler as possible and from one another. For best results, horizontal vent systems should be as short and straight as possible.

When horizontal vent runs exceed **5 ft, 1.5 m** they must be supported at **3 ft, 0.9 m** intervals with overhead hangers. The vent system must be pitched down, toward the vent terminal, **1/4 in/ft, 20 mm/m**. If any part of a single wall metal vent system passes through an unheated space it must be insulated with insulation rated for **400°F, 204°C**.

Horizontal vent systems shall terminate at least **4 ft, 1.2 m** below, **4 ft, 1.2 m** horizontally from or **1 ft, 0.3 m** above any door, window or gravity air inlet into any building. It must not terminate less than **4 ft, 1.2 m** horizontally from, and in no case above or below, unless a **4 ft, 1.2 m** horizontal distance is maintained, from electric meters, gas meters, regulators and relief equipment and not less than **7 ft, 2.1 m** from any adjacent public walkway. The bottom of the vent terminal(s) shall be located at least **5 ft, 1.5 m** above the air intake terminal(s) unless there is a minimum **5 ft, 1.5 m**, horizontal separation between them. Avoid terminal locations likely to be affected by winds, snowdrifts, people and pets. Protect building materials and vegetation from degradation caused by the flue gases.

To determine the appropriate power venter for the boiler/water heater, see Table 6, Power Venter Sizes. Follow the power venter manufacturer’s installation instructions.

Table 6 - Power Venter Sizes

Dominator Model	Power Venter Model	Max. Pipe Length	
		FT	m
300	HS-1	30*	<i>9</i>
400	HS-2	100	<i>31</i>
600	HS-2	67**	<i>21</i>
750-900	HS-3	100	<i>31</i>
1050-1350	HS-4	100	<i>31</i>
1500-2100	HS-5	100	<i>31</i>

*Choose HS-2 for **100 ft, 31 m**, Max. Pipe length
 Choose HS-3 for **100 ft, 31 m, Max. Pipe Length

OUTDOOR VENTING

When installed outdoors the Dominator must be fitted with the factory supplied outdoor vent hood and air intake hood, see Figure 8. Multiple units must be spaced per Figure 9.

The boiler/water heater must be at least **10 ft, 3.0 m** from any door, window or gravity air inlet into any building and at least **3 ft, 0.9 m** from any overhang unless local codes dictate differently.

Avoid locations where wind deflection off of adjacent walls, buildings or shrubbery might cause a down draft. The unit(s) should be located at least **3 ft, 0.9 m** from structures. Outdoor installations are not recommended in areas where the danger of snow blockage exists.

CAUTION: Do not place the boiler/water heater in a location that would subject it to runoff from adjacent buildings or damage may occur voiding the warranty!

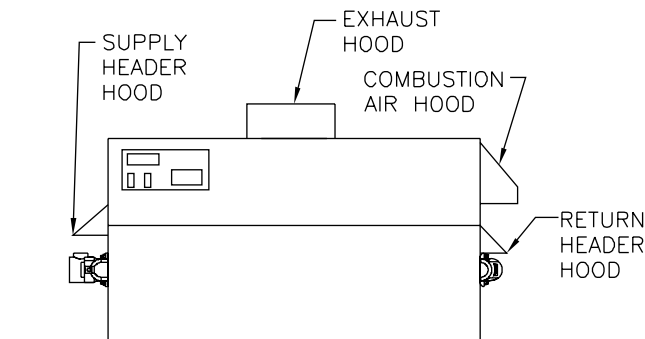
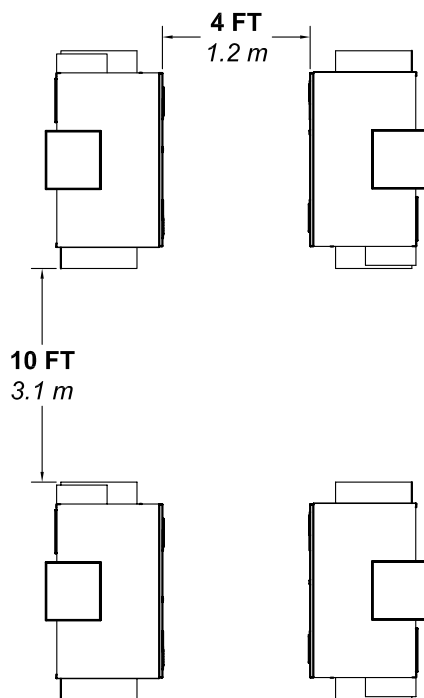
Figure 8 - Outdoor Venting**Figure 9 - Multiple Outdoor Units**

COMMON VENT SYSTEMS

If an existing boiler/water heater is removed from a common venting system, the common venting system may then be too large for the proper venting of the remaining appliances connected to it. At the time of removal of an existing boiler/water heater, the following steps shall be followed with each appliance remaining connected to the common venting system placed in operation, while the other appliances remaining connected to the common venting system are not in operation.

Au moment du retrait d'une chaudière existante, les mesures suivantes doivent être prises pour chaque appareil toujours raccordé au système d'évacuation commun et qui fonctionne alors que d'autres appareils toujours raccordés au système d'évacuation ne fonctionnent pas: système d'évacuation

- a) Seal any unused openings in the common venting system.

Sceller toutes les ouvertures non utilisées du système d'évacuation.

- b) Visually inspect the venting system for proper size and horizontal pitch and determine there is no blockage or restriction, leakage, corrosion and other deficiencies which could cause an unsafe condition.

Inspecter de façon visuelle le système d'évacuation pour déterminer la grosseur et l'inclinaison horizontale qui conviennent et s'assurer que le système est exempt d'obstruction, d'étranglement de fuite, de corrosion et autres défaillances qui pourraient présenter des risques.

- c) Insofar as is practical, close all building doors and windows and all doors between the space in which the appliances remaining connected to the common venting system are located and other spaces of the building. Turn on clothes dryers and any appliance not connected to the common venting system. Turn on any exhaust fans, such as range hoods and bathroom exhaust, so they will operate at maximum speed. Do not operate a summer exhaust fan for a boiler installation. Close fireplace dampers.

Dans la mesure du possible, fermer toutes les portes et les fenêtres du bâtiment et toutes les portes entre l'espace où les appareils toujours raccordés du système d'évacuation sont installés et les autres espaces du bâtiment. Mettre en marche les sècheuses, tous les appareils non raccordés au système d'évacuation commun et tous les ventilateurs d'extraction comme les hottes de cuisinière et les ventilateurs des salles de bain. S'assurer que ces ventilateurs fonctionnent à la vitesse maximale. Ne pas faire fonctionner les ventilateurs d'été. Fermer les registres des cheminées.

- d) Place in operation the appliance being inspected. Follow the lighting instructions. Adjust thermostat so appliance will operate continuously.

Mettre l'appareil inspecté en marche. Suivre les instructions d'allumage. Régler le thermostat de façon que l'appareil fonctionne de façon continue.

- e) Test for spillage at the draft hood relief opening after 5 minutes of main burner operation. Use the flame of a match or candle, or smoke from a cigarette, cigar or pipe.

Faire fonctionner le brûleur principal pendant 5 min ensuite, déterminer si le coupe-tirage déborde à l'ouverture de décharge. Utiliser la flamme d'une allumette ou d'une chandelle ou la fumée d'une cigarette, d'un cigare ou d'une pipe.

- f) After it has been determined that each appliance remaining connected to the common venting system properly vents when tested as outlined above, return doors, windows, exhaust fans, fireplace dampers and any other gas-burning appliance to their previous condition of use.

Une fois qu'il a été déterminé, selon la méthode indiquée cidessus, que chaque appareil raccordé au système d'évacuation est mis à l'air libre de façon adéquate. Remettre les portes et les fenêtres, les ventilateurs, les registres de cheminées et les appareils au gaz à leur position originale.

- g) Any improper operation of the common venting system should be corrected so the installation conforms with the National Fuel Gas Code, ANSI Z223.1/NFPA 54. When resizing any portion of the common venting system, the common venting system should be resized to approach the minimum size as determined using the appropriate tables in Appendix F in the National Fuel Gas Code, ANSI Z223.1/NFPA 54 and or CAN/CGA-B149 Installation Codes.

Tout mauvais fonctionnement du système d'évacuation commun devrait être corrigé de façon que l'installation soit conforme au National Fuel Gas Code, ANSI Z223.1/NFPA 54 et (ou) aux codes d'installation CSA-B149. Si la grosseur d'une section du système d'évacuation doit être modifiée, le système devrait être modifié pour respecter les valeurs minimales des tableaux pertinents de l'appendice F du National Fuel Gas Code, ANSI Z223.1/NFPA 54 et (ou) des codes d'installation CAN/CGA-B149.

GENERAL PIPING REQUIREMENTS

CAUTION: Improper piping of this boiler/water heater will void the manufacturer's warranty and can cause boiler failure resulting in flooding and extensive property damage! Excessive water hardness causing scaling in the copper heat exchanger tubes is NOT covered under the manufacturer's warranty. Excessive pitting and erosion of the internal surface of the copper heat exchanger tubes is NOT covered under the manufacturer's warranty if the result of high water flow rates, see Table 7. Return water temperatures below 125°F, 52°C will result in heat exchanger damage from excessive condensation voiding the manufacturer's warranty, see Primary/Secondary Piping Figure 11.

NOTE: Shut off valves and unions should be installed at the inlet and outlet connections of the boiler/water heater to provide for isolation of the unit should servicing be necessary.

Freeze Protection

This boiler/water heater is CSA designed certified for outdoor installation. Outdoor installations in areas where the danger of freezing exists are not recommended unless proper freeze protection is provided. If the unit is to be installed in such an area the following precautions MUST be observed:

1. A continuous flow of water through the boiler/water heater MUST be maintained! The pump responsible for flow through the boiler/water heater must run continuously!
2. An ethylene glycol/water mixture suitable for the minimum temperature that the unit will be exposed to must be used. The pump must be capable of producing a minimum of 15% more flow and overcoming a 20% increase in head loss. Domestic water systems must be isolated from the water heater by the use of a heat exchanger or other approved method.
3. If the boiler/water heater must be shut off for any reason the electric, gas and water supplies MUST be shut off and the unit and its pump completely drained.

CAUTION: Improper outdoor installation of this boiler/water heater can cause boiler failure voiding the manufacturer's warranty!

Relief Valve

Pipe the discharge of the pressure relief valve to prevent scalding in the event of a discharge, see Figure 10. The discharge piping must be sized the same as the pressure relief valve outlet and installed to allow complete drainage of both the relief valve and the discharge piping.

Figure 10 - Relief Valve Piping

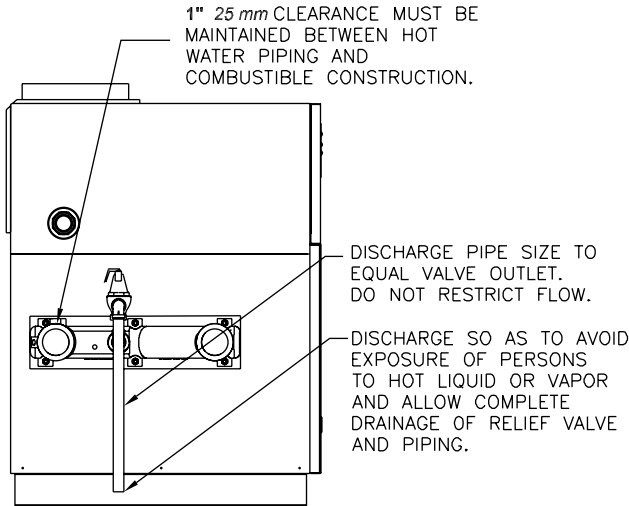

WARNING: Never install any type of valve between the boiler/water heater and the relief valve or an explosion causing extensive property damage, severe personal injury or death may occur!

Flow Switch

The flow switch supplied with the boiler/water heater must be wired to the terminal strip in the control panel to prevent the boiler from firing unless there's adequate water flow through the unit. The flow switch must be installed in the supply piping adjacent to the boiler outlet connection.

CAUTION: Failure to properly install the flow switch may result in damage to the boiler/water heater heat exchanger voiding the warranty!

Table 7 - Temperature Rise Table

		$\Delta T = 15^{\circ}F$		$\Delta T = 8.3^{\circ}C$	
Model Number	Flow Rate GPM	Pres. Drop Ft	Flow Rate L/s	Pres. Drop kPa	
300	34.0	0.22	2.1	0.6	
400	45.4	0.49	2.9	1.5	
600	68.1	1.30	4.3	3.8	
750	85.1	2.35	5.4	6.9	
900	102.1	3.84	6.4	11.3	
1050	119.1*	6.23	7.5	18.4	
		$\Delta T = 20^{\circ}F$		$\Delta T = 11.1^{\circ}C$	
Model Number	Flow Rate GPM	Pres. Drop Ft	Flow Rate L/s	Pres. Drop kPa	
300	25.5*	0.13	1.6	0.4	
400	34.0	0.29	2.1	0.9	
600	51.1	0.76	3.2	2.3	
750	63.8	1.38	4.0	4.1	
900	76.6	2.25	4.8	6.6	
1050	89.4	3.66	5.6	10.8	
1350	114.9*	7.17	7.2	21.1	
		$\Delta T = 25^{\circ}F$		$\Delta T = 13.9^{\circ}C$	
Model Number	Flow Rate GPM	Pres. Drop Ft	Flow Rate L/s	Pres. Drop kPa	
300	20.4*	0.09	1.3	0.3	
400	27.2*	0.19	1.7	0.6	
600	40.8	0.51	2.6	1.5	
750	51.1	0.91	3.2	2.7	
900	61.3	1.49	3.9	4.4	
1050	71.5	2.42	4.5	7.1	
1350	91.9	4.74	5.8	14.0	
1500	102.1	6.31	6.4	18.6	
		$\Delta T = 30^{\circ}F$		$\Delta T = 16.7^{\circ}C$	
Model Number	Flow Rate GPM	Pres. Drop Ft	Flow Rate L/s	Pres. Drop kPa	
600	34.0	0.36	2.1	1.1	
750	42.6	0.65	2.7	1.9	
900	51.1	1.06	3.2	3.1	
1050	59.6	1.73	3.8	5.1	
1350	76.6	3.38	4.8	10.0	
1500	85.1	4.50	5.4	13.3	
1950	110.6*	9.20	7.0	27.1	
2100	119.1*	11.27	7.5	33.2	
		$\Delta T = 35^{\circ}F$		$\Delta T = 19.4^{\circ}C$	
Model Number	Flow Rate GPM	Pres. Drop Ft	Flow Rate L/s	Pres. Drop kPa	
750	36.5	0.49	2.3	1.4	
900	43.8	0.80	2.8	2.4	
1050	51.1	1.30	3.2	3.8	
1350	65.6	2.54	4.1	7.5	
1500	72.9	3.38	4.6	10.0	
1950	94.8	6.91	6.0	20.4	
2100	102.1	8.47	6.4	25.0	

*Flow exceeds recommended maximum use a greater temperature rise or consult manufacturer. Cupro-nickel heat exchanger should be considered.

HEATING SYSTEM PIPING

General Piping Requirements

All heating system piping must be installed by a qualified technician in accordance with the latest revision of the ANSI/ASME Boiler and Pressure Vessel Code, Section IV, and, when required, ANSI/ASME CSD-1, Standard for Controls and Safety Devices for Automatically Fired Boilers. All applicable local codes and ordinances must also be followed. A minimum clearance of **1 in, 25 mm** must be maintained between heating system pipes and all combustible construction. All heating system piping must be supported by suitable hangers not the boiler.

The thermal expansion of the system must be considered when supporting the system. A minimum system pressure of **12 psig, 82.7 kPa** must be maintained.

Heating Boiler Piping Connections

The supply and return piping should be sized to suit the system. The supply and return connection sizes are listed in Table 8.

Table 8 - Supply & Return Connection Sizes

Model Size	Supply	Return
300 thru 2100	2 1/2" NPT	2 1/2" NPT

Pump Requirements

This low mass boiler requires a continuous minimum water flow for proper operation. The system pump must be sized to overcome the head loss of the boiler and the heating system in order to achieve the required temperature rise. Table 7 provides the heat exchanger pressure drop and temperature rise figures. The temperature rise across the boiler must never exceed **35° F, 19.4° C**.

CAUTION: A temperature rise outside of the range listed in Table 7 indicates that the flow rate through the heat exchanger is incorrect which will damage the heat exchanger voiding the warranty! The maximum allowable temperature rise is 35°F, 19.4°C.

The maximum allowable flow rate through a Dominator boiler with copper heat exchanger is 105 GPM, 6.6 L/s. The cupro-nickel heat exchanger allows for 120 GPM, 7.6 L/s.

An adjustable pump delay is available as a feature of the staging controller. The pump delay establishes water flow through the boiler and heating system before the appliance starts. Consult the staging controller manual for further details.

Low Water Cutoff

If a boiler is installed above any radiation elements it must be fitted with a low water cutoff device.

Refer to wiring diagram supplied with the boiler/water heater for proper wiring connections.

Expansion Tank & Air Separator

An expansion tank or other means to control thermal expansion must be installed in the heating system. An expansion tank must be installed close to the boiler on the suction side of the pump. An air scoop and automatic air vent must also be installed to eliminate air trapped in the system.

Primary/Secondary Piping

Boilers connected to heating systems using zone valves, zone pumps, or systems that have excessive flow rates or return water temperatures less than **125°F, 52°C** must be isolated from these systems to protect the boiler.

Variable Water Flows

Figure 11 shows a typical primary/secondary piping system. A dedicated pump is used to maintain a constant water flow through the boiler. This secondary pump is sized to overcome the head loss of the boiler and secondary piping system while supplying the flow rate required to maintain the desired temperature rise across the boiler. The primary pump is sized to provide the required flow to the heating system. The secondary piping connections to the primary system piping must not be more than **12 in, 305 mm** apart to ensure zero pressure drop in the primary system, see Figure 11.

Low Return Water Temperatures

To prevent the problems associated with condensation of the products of combustion due to low return water temperatures a primary/secondary piping system with a bypass and bypass valve must be installed, see Figure 12. The bypass and bypass valve must be sized the same as the secondary piping. A balancing valve must also be installed in the supply side of the secondary piping downstream of the bypass. The balancing valve should be adjusted to divert some of the heated discharge water into the return water until the required inlet water temperature is achieved. The primary and secondary pumps should be sized to provide the required flow through each system. The secondary piping connections to the primary system piping must not be more than **12 in, 305 mm** apart to ensure zero pressure drop in the primary system, see Figure 12.

Multiple Boiler Systems

Systems using multiple boilers can also be installed using a primary/secondary manifold system, Figure 13.

Piping For Use With Cooling Units

The boiler, when used in connection with a refrigeration system, must be installed so the chilled medium is piped in parallel with the boiler. Appropriate valves must be used to prevent the chilled water from entering the boiler.

When a boiler is connected to a heating coil that may be exposed to refrigerated air from an air handling device, the piping system must be equipped with flow-control valves or some other automatic means of preventing gravity circulation of the boiler water during the cooling cycle.

Figure 11 - Typical Primary/Secondary Piping System
(See Notes)

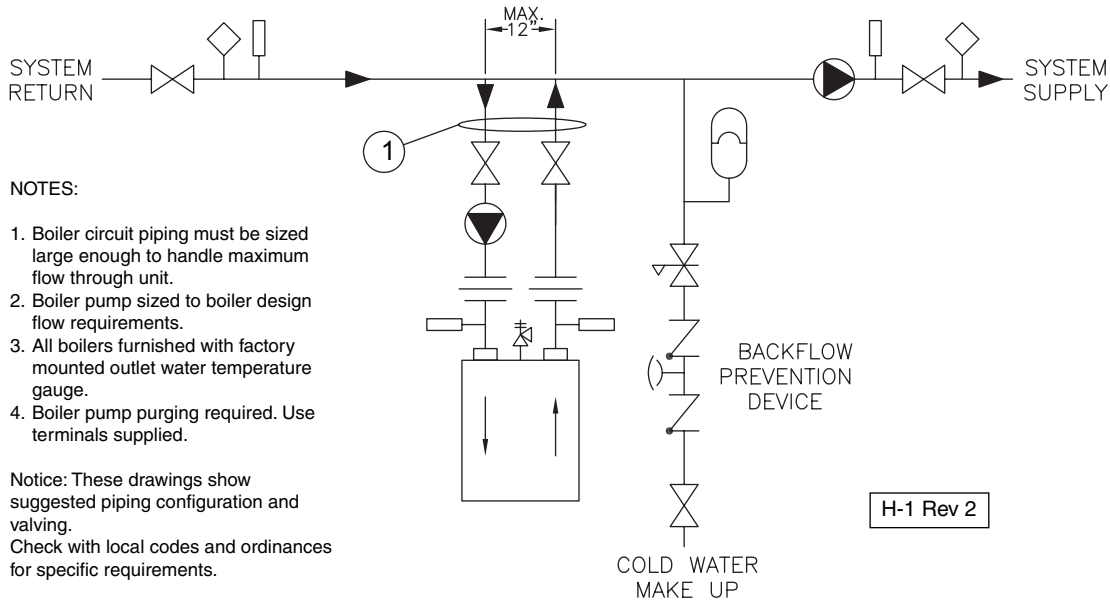

NOTES:

1. Boiler circuit piping must be sized large enough to handle maximum flow through unit.
2. Boiler pump sized to boiler design flow requirements.
3. All boilers furnished with factory mounted outlet water temperature gauge.
4. Boiler pump purging required. Use terminals supplied.

Notice: These drawings show suggested piping configuration and valving. Check with local codes and ordinances for specific requirements.

H-1 Rev 2

Figure 12 - Low Temperature Piping with Thermostatic Piping
(See Notes and Adjustment Procedures)

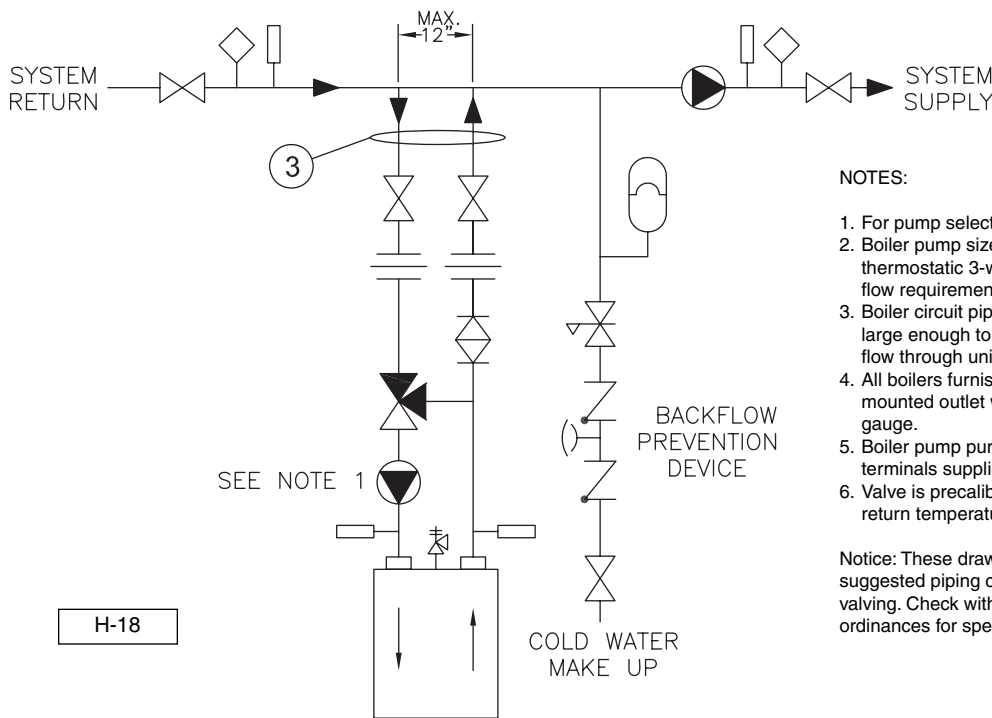

NOTES:

1. For pump selection consult factory.
2. Boiler pump sized to boiler and thermostatic 3-way valve design flow requirements.
3. Boiler circuit piping must be sized large enough to handle maximum flow through unit.
4. All boilers furnished with factory mounted outlet water temperature gauge.
5. Boiler pump purging required. Use terminals supplied.
6. Valve is precalibrated for 140°F return temperature.

Notice: These drawings show suggested piping configuration and valving. Check with local codes and ordinances for specific requirements.

H-18

	Pump
	Gate Valve
	Globe Valve
	Angle Valve
	Butterfly Valve
	Balance Valve
	Ball Valve
	Motorized Valve
	Solenoid Operated Valve
	Self-Operated Valve
	Pressure Reducing Valve
	Check Valve
	Pressure Relief Valve
	Flow Switch
	Thermometer
	Aquatast Union
	Pressure Switch
	Gas Pressure Regulator
	Automatic Air Vent
	Backflow-Prevention Device
	3-Way Valve
	Expansion Tank

Adjustment Procedure To Maintain Inlet Temperature Above Dew Point
T1-Temp-Min=110° For Atmospheric
T1-Temp-Min=125° Sealed Combustion

1. Turn heater on and open valves A & B.
2. After steady-state operation, if T1 is less than Temp-Min slowly close valve B until T1 climbs to desired operating temperature above Temp-Min.
3. If T1 is greater than desired operating temperature, slowly close valve A to adjust to lower desired temperature above Temp-Min.
4. Check after system operating temperature has stabilized. Make final adjustments.
5. Follow same adjustment procedure for sealed combustion.

Figure 12A - Low Temperature Heat Pump
(See Notes and Adjustment Procedures)

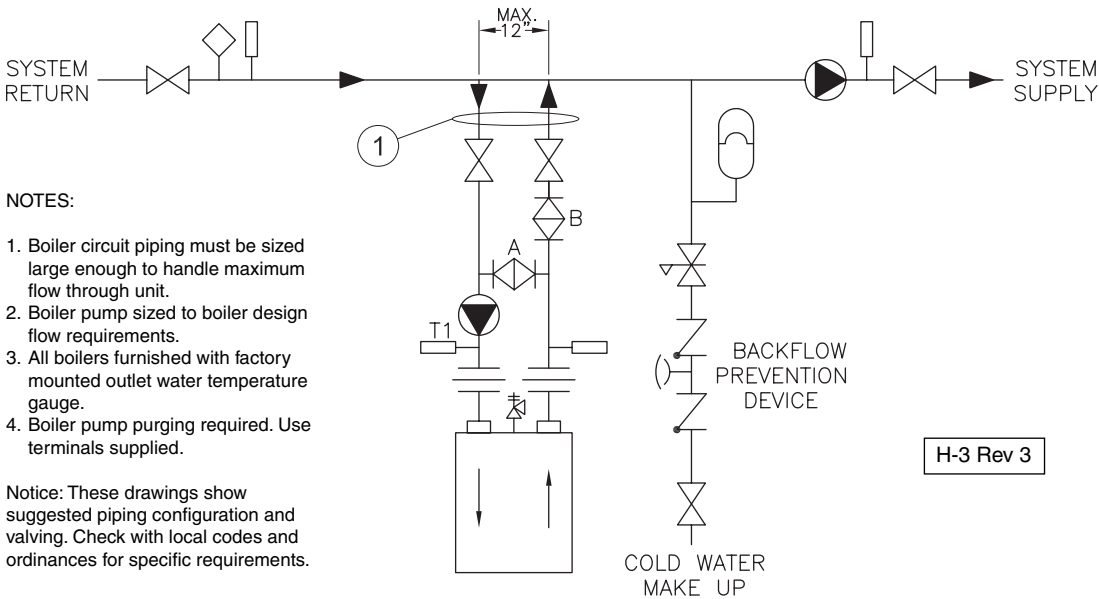

NOTES:

1. Boiler circuit piping must be sized large enough to handle maximum flow through unit.
2. Boiler pump sized to boiler design flow requirements.
3. All boilers furnished with factory mounted outlet water temperature gauge.
4. Boiler pump purging required. Use terminals supplied.

Notice: These drawings show suggested piping configuration and valving. Check with local codes and ordinances for specific requirements.

H-3 Rev 3

Figure 13 - Multiple Boiler Piping
(See Notes)

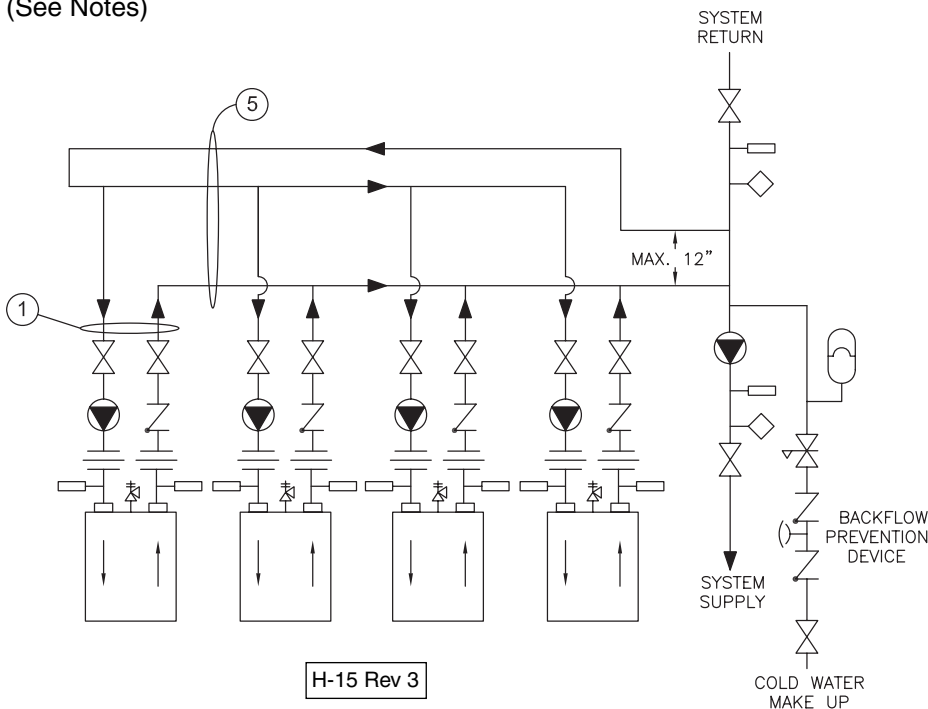

NOTES:

1. Boiler circuit piping must be sized large enough to handle maximum flow through unit.
2. Boiler pump sized to boiler design flow requirements.
3. All boilers furnished with factory mounted outlet water temperature gauge.
5. Boiler pump purging required. Use terminals supplied.
6. Secondary loop pipe diameter must be sized large enough to handle maximum flow through all units.

Notice: These drawings show suggested piping configuration and valving. Check with local codes and ordinances for specific requirements.

H-15 Rev 3

	Pump
	Gate Valve
	Globe Valve
	Angle Valve
	Butterfly Valve
	Balance Valve
	Ball Valve
	Motorized Valve
	Solenoid Operated Valve
	Self-Operated Valve
	Pressure Reducing Valve
	Check Valve
	Pressure Relief Valve
	Flow Switch
	Thermometer
	Aquatat Union
	Pressure Switch
	Gas Pressure Regulator
	Automatic Air Vent
	Backflow-Prevention Device
	3-Way Valve
	Expansion Tank

Adjustment Procedure To Maintain Inlet Temperature Above Dew Point

Above Dew Point
T1-Temp-Min=110° For Atmospheric
T1-Temp-Min=125° Sealed Combustion

1. Turn heater on and open valves A & B.
2. After steady-state operation, if T1 is less than Temp-Min slowly close valve B until T1 climbs to desired operating temperature above Temp-Min.
3. If T1 is greater than desired operating temperature, slowly close valve A to adjust to lower desired temperature above Temp-Min.
4. Check after system operating temperature has stabilized. Make final adjustments.
5. Follow same adjustment procedure for sealed combustion.

DOMESTIC WATER SUPPLY PIPING

CAUTION: Proper control settings must be used to prevent water supplied for domestic use from exceeding 130°F, 54°C or a scald injury will occur! When higher water temperatures are required for appliances such as a dishwasher, a mixing valve or some other tempering means must be installed. Households with small children may require water temperatures less than 120°F, 49°C. Local codes must be complied with!

General Piping Requirements

Ensure that the water heater is equipped with bronze headers. Piping and components connected to the water heater must be suitable for use with potable water. The water heater must not be connected to any heating system piping or components previously used with a non-potable water heating appliance. No toxic chemicals, such as those used for boiler treatment, are to be introduced into the potable water used for space heating. If a hot water storage tank is used in the system it must be equipped with a temperature and pressure relief valve that complies with ANSI Z21.22 or CAN-4.4 and CAN-4.6.

NOTE: The storage tank must be located as close to the water heater as possible to prevent excessive head loss which will reduce flow.

Water Chemistry

The required temperature rise across the water heater is based on water having a hardness between 8 and 18 grains per gallon with a level of dissolved solids not exceeding 350 ppm. Water having a hardness less than 8 grains can cause excessive erosion of the heat exchanger. Water that has a hardness greater than 18 grains per gallon and/or a level of dissolved solids exceeding 350 ppm will require a recalculation of the pump size and temperature rise.

A cupro-nickel heat exchanger may also be required. The manufacturer should be consulted when these water conditions are encountered. See Table 8A.

CAUTION: The maximum allowable flow rate through a Dominator water heater with copper heat exchanger is 105 GPM, 6.6 L/s. The cupro-nickel heat exchanger allows for 120 GPM, 7.6 L/s, see Table 8B.

RBI water heaters are designed to run scale free. Due to the extreme variables of water conditions world wide it is necessary to consider pH values and water hardness in relationship to scaling. It is crucial to consider these two variables when making heat exchanger and pump selection. If local water conditions are extreme follow the guidelines in the Heat Exchanger Selection Table (Table 8A) and the Pumping Performance Table (Table 8B). Scale free operation can be achieved by using water with a hardness between 8 and 18 and by maintaining the pH between 5 and 9. Follow the conditions listed under NORMAL in the table. In some areas of the country additional precautions must be observed due to unusual characteristics of the local water supply. Call the nearest RBI representative for details.

To properly size the pump a grain hardness and pH test must be taken at the installation site before the order is placed. Proper pump sizing will improve heater performance and help ensure heater longevity.

Table 8A - Dominator Heat Exchanger Selection Graph

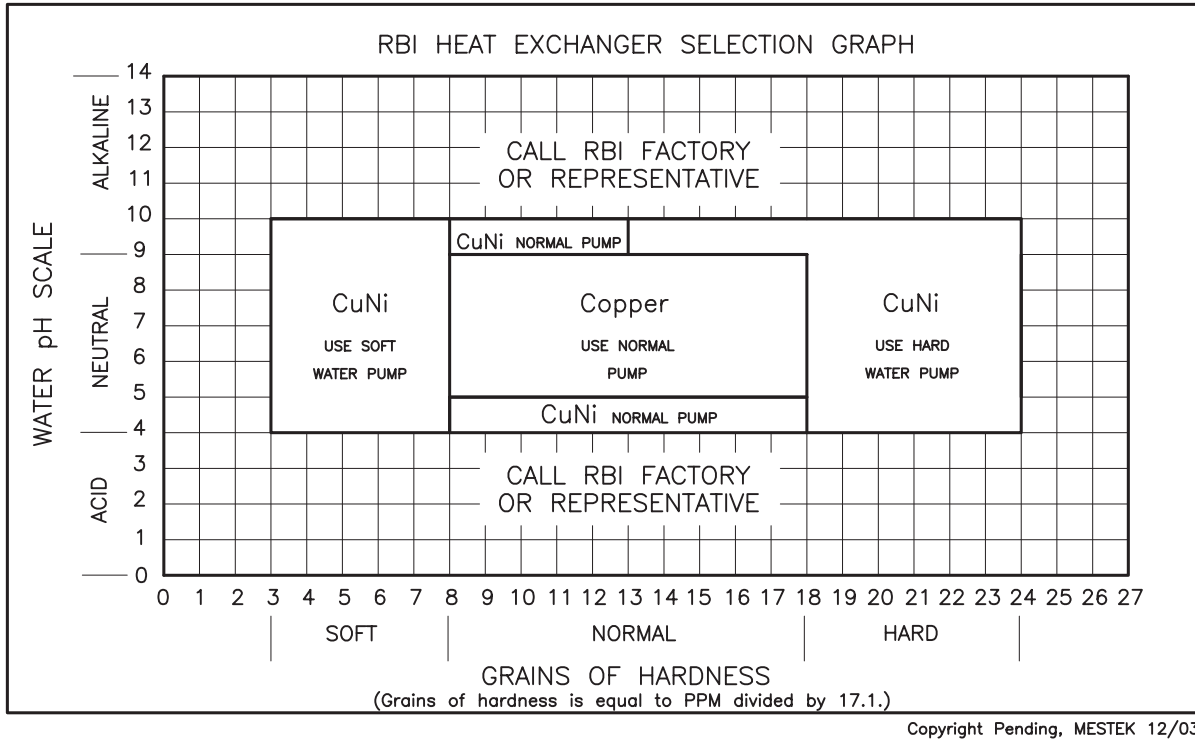

Table 8B - Dominator Pumping Performance Requirement

DOMINATOR PUMPING PERFORMANCE REQUIREMENTS

WATER HARDNESS HEAT EXCH. TYPE	SOFT			NORMAL			HARD		
	CuNi			Copper			CuNi		
MODEL	GPM	ΔP	ΔT	GPM	ΔP	ΔT	GPM	ΔP	ΔT
DW-300	37	0.26	14.0	75	0.95	7.0	112	2.00	5.0
DW-400	37	0.35	18.0	75	1.25	9.0	112	2.65	6.0
DW-600	37	0.43	27.0	75	1.56	14.0	112	3.30	9.0
DW-750	37	0.52	34.0	75	1.86	17.0	112	3.94	11.0
DW-900	37	0.60	41.0	75	2.17	20.0	112	4.59	14.0
DW-1050	37	0.73	48.0	75	2.64	24.0	112	5.60	16.0
DW-1350	37	0.90	61.0	75	3.25	31.0	112	6.89	20.0
DW-1500	37	0.99	68.0	75	3.56	34.0	112	7.54	23.0
DW-1950	37	1.24	88.0	94	6.76	35.0	112	9.48	29.0
DW-2100	37	1.32	95.0	103	8.62	35.0	112	10.13	32.0

ΔT=Temperature Change=(Outlet Temp.-Inlet Temp.) in F.
 ΔP=Head Loss=(Inlet Pres.-Outlet Pres.) in feet of Water Column.
 To achieve the proper flow rate adjust outlet valve on heater piping to obtain the correct ΔT.
 Call factory if grains of hardness is less than 3 or greater than 24.

SPECIAL REQUIREMENTS
 (CALL FACTORY OR REPRESENTATIVE)

Copyright Pending, MESTEK 12/03

Expansion Tank

An expansion tank or other means to control thermal expansion must be installed in the water heating system if back flow prevention devices are installed.

Cold Water Supply

The cold water supply must be piped to the water heater's outlet piping between the water heater and the hot water storage tank. This will prevent untempered water from entering the water heater, see the Temperature Rise Control section below. A typical water heating system is shown in Figure 14 and 15.

Pump Requirements

This low-mass water heater requires a continuous minimum water flow for proper operation. The low water flow switch provided for this unit will shut down the water heater if flow falls below the required minimum level. Table 8B provides the heat exchanger pressure drop chart and temperature rise table. **The temperature rise across the water heater must never exceed 35°F, 19°C.**

Temperature Rise Control

Water returned to the water heater inlet must not be less than **125°F, 52°C** or excessive condensation of the products of combustion will damage the water heater voiding the warranty. The method outlined below can be employed to prevent this condition from occurring.

A balancing valve should be installed on the outlet side of the water heater for purposes of adjusting the flow rate through the heat exchanger. Thermometers are installed on both the inlet and outlet of the water heater for determining the temperature rise through the unit. The proper velocity through the water heater must be maintained in accordance with Table 8B for efficient operation and long life. If the temperature rise through the water heater is lower than recommended the water velocity is too high. Premature erosion of the heat exchanger will occur. Conversely, if the temperature rise is higher than recommended in Table 8B the flow rate is too low. Scaling and softening of the heat exchanger will occur.

Thermostatic Mixing Valve - Water Above 140°F, 60°C
Water can be stored at temperatures above **140°F, 60°C** provided that a thermostatically controlled mixing valve is used to temper the hot water to an acceptable temperature before it's supplied for domestic use.

The mixing valve **MUST** be set to prevent a scald injury from occurring, see the caution against scalding above.

Storage of water for domestic use above **140°F, 60°C** will provide an increased quantity of tempered water and help prevent the growth of water born bacteria.

Figure 14 - Typical Water Heating Piping (DW Models only)
(See Notes)

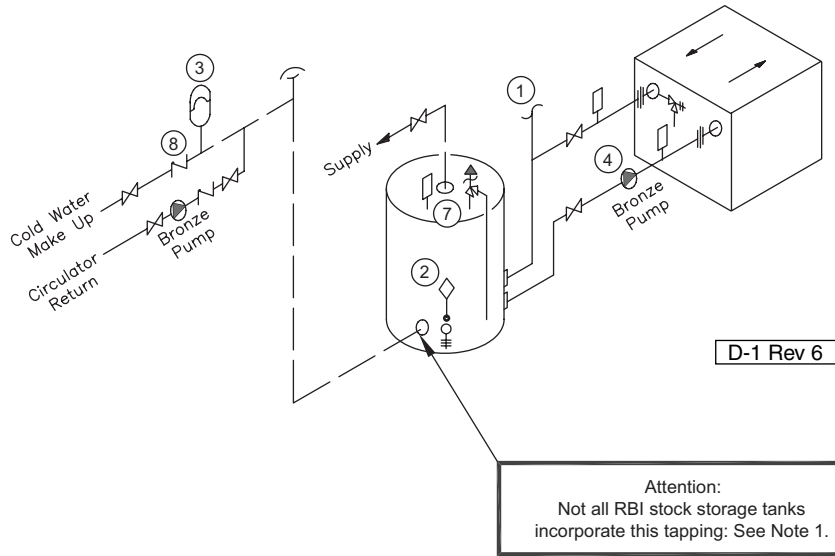

LEGEND:

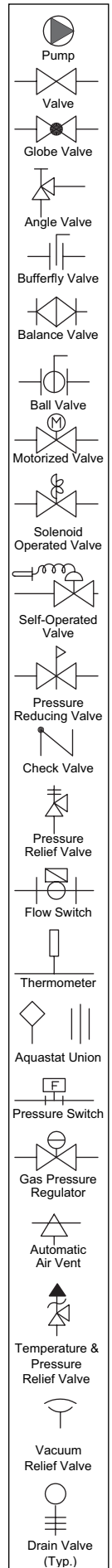
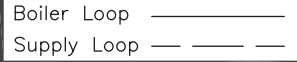
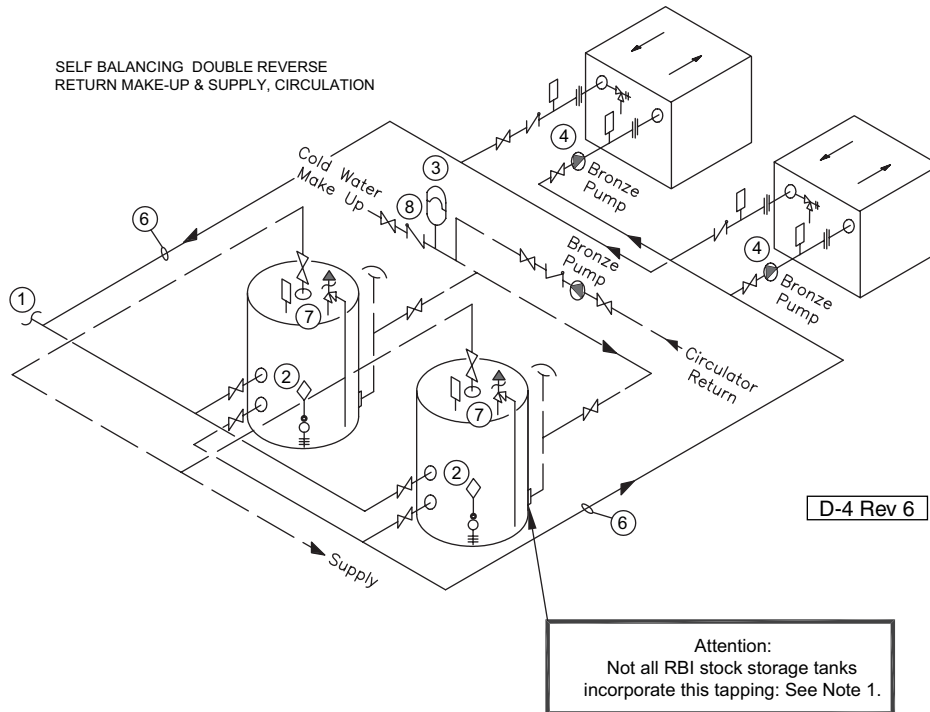

Figure 15 - Multiple Water Heating Piping (DW Models only)
(See Notes)



NOTES:

1. Optional cold water make up and recirculation line location.
2. When using intermittent pump and pump delay, locate remote aquastat well in lower 1/3 of tank. Install aquastat with heat sensing compound.
3. Thermal expansion tank may be required, check local codes.
4. When using optional factory mounted pump, max pipe length 30' total, 6-90° elbows, full pipe size.
5. CAUTION: MEASURE WATER HARDNESS AND pH AT JOB SITE.
The pH and water hardness must be measured before selecting heat exchanger and pump. Consult the Heat Exchanger Graph and Pumping Performance Table before making selection.
6. Common piping must be sized for maximum combined heater flow.
7. Hot water tanks should be equipped with a combination temperature & pressure relief valve.
8. MA Code requires an 1/8" hole in check valve to compensate for thermal expansion.

Notice: These drawings show suggested piping configuration and valving. Check with local codes and ordinances for specific requirements.

GAS SUPPLY PIPING

WARNING: Check the boiler/water heater rating plate to make sure that the boiler/water heater is for the type of gas that will be used. If it isn't, do not connect the boiler/water heater to the gas supply. Gas supply piping must be in accordance with the National Fuel Code, ANSI Z223.1-latest revision or applicable provisions of the local building codes. Canadian installations must comply with CAN/CGA B149.1 or .2 Installation Code. Failure to comply with this warning can result in extensive property damage, severe personal injury or death!

The Dominator comes from the factory ready to be piped to the gas supply. If for any reason the boiler/water heater is not for the type of gas available at the installation site, call your RBI representative to resolve the problem.

NOTE: A minimum gas supply pressure of 6 in, 152 mm W.C. natural or 11 in, 279 mm W.C. propane and maximum 14 in, 356 mm W.C. natural or propane, must be available at the safety shutoff valve inlet with the unit(s) operating.

Table 9 should be used to ensure that the gas supply piping is sized properly. If more than one appliance is supplied by the same supply pipe, the piping must be sized based on the maximum possible demand. Do not neglect the pressure drop due to pipe fittings. Table 9 should be used in conjunction with Table 10 to ensure that the gas supply piping has the capacity to meet the demand.

Figure 16 depicts the proper way to connect the boiler/water heater to the gas supply piping. The manual shut-off valve must be installed in the supply piping. It should be installed **5 ft, 1.5 m** above the floor where required by local codes. Provide a sediment trap at the bottom of the vertical section of the gas supply pipe upstream of the gas controls.

A ground joint union should be installed between the boiler gas controls and the supply piping. Each of these items are needed to ensure long life and ease of servicing. Always use a pipe sealant that is suitable for use with LP gas.

Table 9 - Gas Pipe Capacity

Maximum pipe capacity in ft ³ /hr based on 0.60 specific gravity gas at a pressure of 0.5 psig or less and a 0.3" W.C. pressure drop.									
Nominal Iron Pipe Size, (in)	Pipe length in feet								
	10	20	30	40	50	60	80	100	150
	Maximum gas volume of pipe, (ft ³ /hr)								
1"	520	350	285	245	215	195	170	150	120
1 1/4"	1050	730	590	500	440	400	350	305	250
1 1/2"	1600	1100	890	760	670	610	530	460	380
2"	3050	2100	1650	1450	1270	1150	990	870	710
2 1/2"	4800	3300	2700	2300	2000	1850	1600	1400	1130
3"	8500	5900	4700	4100	3600	3250	2800	2500	2000

Note: Multiply the gas volume by 0.62 for propane flow capacity in ft³/hr. Multiply the propane flow capacity by 2500 Btu/ft³ to determine the propane Btu/hr capacity for a given pipe size and length.

Table 10 - Equivalent Pipe Length Chart

Nominal Iron Pipe Size, (in)	Type of pipe fitting			
	90° Elbow	Tee ¹	Gas Valve ²	Gas Cock ²
	Equivalent pipe length, (ft)			
1"	2.6	5.2	0.6	1.5
1 1/4"	3.5	6.9	0.8	1.9
1 1/2"	4.0	8.0	0.9	2.3
2"	5.2	10.3	1.2	3.0
2 1/2"	6.2	12.3	1.4	3.7
3"	7.7	15.3	1.8	4.5

Notes: 1. For flow through branch.
2. For flow at full open.

CAUTION: Always use a square jawed wrench on the gas valve body when making gas connections to it. Never over-tighten the piping entering the gas valve body or gas valve failure may result!

Figure 16 - Gas Supply Piping

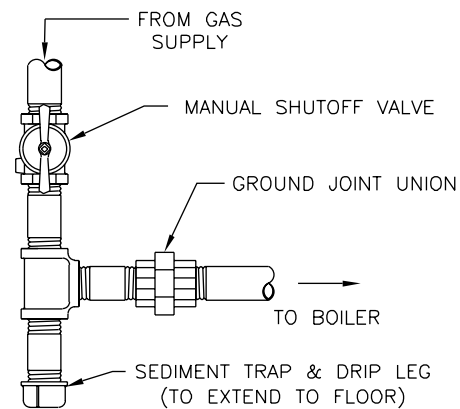

When applicable, provisions for vent, bleed and gas relief lines must be made in accordance with the latest revision of ANSI Z223.1/NFPA 54.

Safe lighting and other performance criteria were met with the gas manifold and control assembly provided on the boiler. All gas connections **MUST** be leak tested before putting the boiler into operation.

WARNING: Never use an open flame to test for gas leaks. Always use an approved leak detection method. Failure to comply with this warning can cause extensive property damage, severe personal injury or death!

Whenever the gas supply piping is pressure tested the boiler/water heater gas controls must be protected. If the test pressure is equal to, or less than **1/2 psig, 3.5 kPa** isolate the boiler/water heater by closing its manual shut off valve, see Figure 16. If the test pressure is greater than, or equal to **1/2 psig, 3.5 kPa**, disconnect the boiler/water heater and its individual shut-off valve.

ELECTRICAL WIRING

Electrical Power Connections

CAUTION: Label all wires prior to disconnection when servicing controls. Wiring errors can cause improper and dangerous operation! Verify proper operation after servicing.

ATTENTION. Au moment de l'entretien des commandes, étiquetez tous les fils avant de les débrancher. Des erreurs de câblage peuvent entraîner un fonctionnement inadéquat et dangereux. S'assurer que l'appareil fonctionne adéquatement une fois l'entretirn terminé.

The electrical connections to this boiler/water heater must be made in accordance with all applicable local codes and the latest revision of the National Electrical Code, ANSI /NFPA-70. Installation should also conform with CSA C22.1 Canadian Electrical Code Part I if installed in Canada.

Install a separate 120 volt 15 amp or 20 amp circuit breaker for the boiler/water heater and pump, see Table 11. A properly rated shut-off switch should be located at the boiler/water heater. The boiler/water heater must be grounded in accordance with the authority having jurisdiction, or if none, the latest revision of the National Electrical Code, ANSI/NFPA-70.

Table 11 - Dominator Electrical Requirements

Dominator Model	Recommended Circuit Breaker (Amps)	*Running Amps
DB/DW 300-600	15	3.9
DB/DW 750-900	15	6.0
DB/DW 1050-2100	20	11.4

*Use separate circuit breaker that is properly sized for pump and pump contactor.

Line voltage field wiring of any controls or other devices must conform to the temperature limitation of type T wire at **95°F, 35°C** above room temperature. Use copper conductors with a minimum size of #14 awg. Use appropriate wiring materials for units installed outdoors. The wire size must be compatible with the total amp draw of the circuit.

Refer to the wiring diagram supplied with the boiler/water heater for proper wiring connections.

GENERAL OPERATION

WARNING: Before proceeding read and fully understand the instructions contained in this manual. Do not attempt to operate this boiler/water heater if it has not been installed in accordance with the guidelines set forth in this manual. Failure to comply with this warning can result in extensive property damage, severe personal injury or death!

Should overheating occur or the gas supply fail to shut off, turn off the manual gas control valve to the appliance. Do not interrupt water flow through the boiler/water heater.

En cas de surchauffe ou si l'alimentation en gaz ne s'arrête pas, fermez manuellement le robinet d'arrêt de l'admission de gaz.

Hydronic Heating Boilers

Open the make-up water valve and slowly fill the boiler and all of the radiation with water. Ensure that all bleed and drain valves are closed.

Adjust the make-up water pressure regulator so a minimum **12 psig, 82.7 kPa** system pressure is maintained at the highest point in the system piping. If a make-up water pump is used adjust it to maintain a minimum **12 psig, 82.7 kPa** system pressure.

Open the system bleed and drain valves, one at a time, to purge the air trapped in the heating system piping.

With the boiler off, run the system pump for at least 30 minutes and bleed the system piping using the bleed valves. If strainers are used in the system piping, the make-up water valve should be closed and the strainers checked and cleaned.

The system expansion tank should be checked to ensure that the correct water level in the tank is maintained. The tank should be less than half full of water with the system full and adjusted to the correct operating pressure.

Start the boiler as described in the “OPERATING INSTRUCTIONS”. Run the boiler for at least an hour. The system pump(s) and all radiation units must be operated during this time. Ensure that the make-up water valve is open.

Shut the boiler off and open the bleed valves to purge the air trapped in the heating system piping. Close the make-up water valve and check and clean the strainers and make-up water pressure reducing valve.

Open the make-up water valve and adjust the system pressure if necessary. The system should be checked and bled after three days of operation.

BOILER/WATER HEATER OPERATION

Staging Operation

The Dominator boiler/water heater series is separated into 2-stage and 4-stage units depending on the model size. The 300 through 2100 models have two firing inputs. The 1050 through 2100 have four. Input staging is controlled from the staging controller that signals the relay board to select the blower and gas valve modes. Table 12 identifies the stages and firing modes associated with the 2 stage units (D300-D2100), and Table 13 identifies the stages and firing modes associated with the 4 stage units (D1050-D2100).

Table 12 - Firing Modes (D300-D2100)

Stage	Firing Mode
Off	Off
1	Low Fire
2	High Fire

Table 13 - Firing Modes (D1050-D2100)

Stage	Left Firing Mode	Right Firing Mode
Off	Off	Off
1	Low Fire	Off ¹
2	Low Fire	Low Fire
3	High Fire	Low Fire
4	High Fire	High Fire

1-The left main valve will operate at low fire, but left and right blowers will be on and operating at low fire (low speed).

The outlet water temperature is automatically controlled by the staging controller. It utilizes inputs from the inlet and outlet water temperature sensors, plus optional tank and outside sensors, to stage the boiler/water heater. The Dominator will stage up or down progressively, but will not jump over a stage. Stage 1 will operate first, last and whenever the boiler/water heater is in operation. Consult the staging controller documentation for further information on controller operation.

For the D1050-D2100, the air inlet plenum is divided into left and right sides. A separate blower, main gas valve and manifold are used for each side. However, the combustion chamber is undivided. For best overall performance, gas and airflows should be balanced so that when both sides are at low or high fire, stage 2 or 4, the gas and airflows are equal.

Pressure Switch Settings

Differential pressure switches are provided in the Dominator to shut down gas flow under a blocked flue or inlet condition. One low fire and one high fire pressure switch are used for the 300 through 900 models. Two low fire and two high fire pressure switches are used for the 1050 through 2100 models. The low fire pressure switches serve to shut down gas flow if there is a blocked flue or inlet condition during low fire operation. Similarly, the high fire switches will shut down gas flow if there is a blocked flue or inlet condition during high fire operation. **The differential pressure is taken between the air plenum and the pressure inside one of the main burners.**

Pressure taps are provided in the control compartment for taking the differential pressure readings, Figure 17. Table 14 lists the differential pressure settings for all of the models.

Figure 17 - Pressure Switch Tap(s)

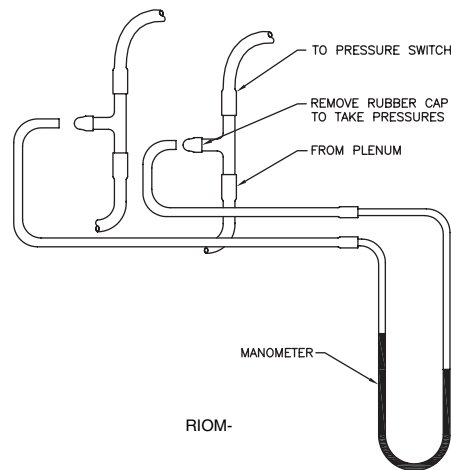

Table 14 - Differential Pressure Settings (All Units)

Model	Differential Pressure Requirement at High Fire (All Units)	
	Inches W.C.	mm W.C.
300-900	0.80 ± 0.1	20.3 ± 2.5
1050-2100	0.90 ± 0.1	22.9 ± 2.5

On the four stage units, the left low fire and high fire switches will interrupt power to the control module under a blocked flue or inlet condition. This will cause the pilot and left and right main gas valves to close. The right switches will only shut down the right main gas valve under a blocked flue or inlet condition. The relay board automatically selects between pressure switches as the boiler/water heater changes stages. Tables 15 and 16 identify how pressure switch control changes during boiler/water heater staging. Tables 17 and 18 identify the control actions if a low air condition occurs at any stage.

For example, when operating at stage 2, the left and right low fire pressure switches monitor the boiler/water heater, since the blowers are operating at low speed. When the unit stages to stage 3 the left blower will be switched to high speed and the relay board will switch the circuit so that the left high fire switch monitors the differential pressure for the left side. The right low fire pressure switch will continue to control the right side until the unit stages to stage 4. At that point, the right high fire pressure switch will automatically take over monitoring duties for the right side. A low air condition in either plenum will cause a red light to illuminate on the indicator board.

Table 15 -Pressure Switch Control, D300-D2100

Stage	Pressure Switch Mode
1	Low Fire
2	High Fire

Table 16 - Pressure Switch Control, D1050-D2100

Stage	Pressure Switch Mode	
1	Left Low Fire	N/A ¹
2	Left Low Fire	Right Low Fire
3	Left High Fire	Right Low Fire
4	Left High Fire	Right High Fire

¹ At Stage 1, the right main valve will not be energized.

Table 17 - Low Air Condition Action, D300-D2100

Stage	Control Action
1	No Power to Ignition Module
2	No Power to Ignition Module

Table 18 - Low Air Condition Action, D1050-D2100

Stage	Left Side	Right Side
1	No Power to Ignition Module	N/A
2	No Power to Igniton Module	No Power to Right Valve
3	No Power to Ignition Module	No Power to Right Valve
4	No Power to Ignition Module	No Power to Right Valve

OPERATION SEQUENCE, 2 STAGE D300 THROUGH D900

Note: On Models D1050-2100, 2 stage, factory jumpers are installed on remote staging terminal strip to force 2 stage operation. Refer to the included connection and wiring diagrams for further control system information.

POWER ON:

Demand for Heat:

1. BTC staging control starts pump and begins 50 second delay before energizing Stage 1.
2. Stage switch 1 closes.
3. System checks primary limit and other interlocks. Will not start if either switch is open.

Prepurge:

1. TDR1 energizes starting a 40 second prepurge cycle.
2. K3 energizes the low speed side of the blower. If the side wall vent option is used the power venter is energized, closing the power venter interlock. The power vent indicator light illuminates.
3. The low air indicator light will remain lit until the blower comes up to speed. The indicator light will turn off and prepurge indicator light will illuminate when the pressure switches make.
4. At the end of the prepurge cycle TDR1 times out. K3 opens and the prepurge indicator light goes out. K2 closes sending 24V ac to the ignition control.
5. K2 will switch the pilot valve, main valve and blower to the high or low fire mode, depending on the staging control input.

Ignition Trial:

1. Once energized, the flame sense module (FSM) initiates 4 second diagnostic cycle before sending 24V ac to the PV terminal and energizing the ignition transformer.
2. The flame failure LED will be lit during the 4 second diagnostic cycle unless the unit is configured for CSD-1. When the PV terminal energizes, the LED will turn off. If the ignition trial fails, the LED will relight.
3. The pilot valve and ignition transformer are energized for the 10 second ignition trial. The pilot indicator light illuminates during this time.
4. If the ignition attempt is unsuccessful, the ignition module will retry in 5 minutes.
5. Since the staging controller remains powered, it will continue to stage up for as long as the call for heat exists. The blower, pump and power venter will remain for as long as a call for heat exists.

6. If the second ignition attempt is unsuccessful the gas valves will lockout, but the blower, pump and power venter will remain on. To reset the boiler/water heater, take one of the following steps:
 - Adjust the high limit down below the point at which the blower shuts down, then reset the limit to its normal setting.
 - Remove power from the boiler/water heater, wait 30 seconds and re-establish power to the unit.
7. On CSD-1 applications the blower and power venter will shut down and the boiler/water heater will lock out. The unit must be manually reset.

Main Burner:

1. Once the pilot is proved the MV terminal on (FSM) is energized sending 24V ac to the main gas valve.
2. The main gas valve opens via action of K1.
3. The main burner indicator light illuminates. The PV terminal remains energized and the pilot indicator remains on.

Normal Operation

- Staging will be controlled from the staging controller.
- The front control panel separately monitors limit, gas pressure, water flow and airflow.
- If staging changes during operation, the blower, pressure switches and gas valves will be switched or turned off as required.
- Stage 1 will operate first and last.

NOTE: For a change from stage 1 to 2, a 10 second DOM time delay is provided in the pressure switch switching circuit (TDR2). The time delay provides a hold state that allows the blower to reach full speed and close the high fire pressure switch before it is energized to confirm proper air flow.

Demand Satisfied:

1. Stage switch 1 opens, TDR1 de-energizes.
2. Power is removed from ignition module, blower and power venter.
3. All indicator lights turn off except for the power indicator light.
4. Staging controller initiates a pump purge for 20 or more seconds, depending on the inlet/outlet temperatures and ΔT setting in the controller. The pump then shuts off.

Staging Control Alarms:

1. Staging control alarms are visible on the controller's LCD screen. See the staging control documentation for details.
2. A powered alarm contact (2A max @ 24 VAC) is available to provide an audio or visual indication of faults related only to the staging control's operation. This contact is wired to the junction box for optional remote indication. Refer to the 2 stage connection diagram for tie-ins.

High Limit, Low Water Flow, Low Gas Pressure, High Gas Pressure, Power Venter Interlock Faults

1. All gas valves, the blower and power venter will be off if either alarm is tripped.
2. The manual reset high limit can be reset through a knockout accessible in the left side jacket panel.
3. Condition indicators are visible on the control panel.

Low Air (Blocked Flue/Air Inlet)

- One of two pressure switches will monitor blower airflow.
- Air monitoring will begin at prepurge. If a low air condition is present, power will not be supplied to the ignition module. The blower will remain on and the low air indicator will remain on for as long as stage 1 remains energized.
- A low air indicator is visible on the control panel.

OPERATION SEQUENCE, 4 STAGE D1050 THROUGH D2100

Note: Refer to the included connection and wiring diagrams for further control system information.

POWER ON:

Demand for Heat:

1. BTC staging control starts pump and begins 50 second delay before energizing Stage 1.
2. Stage switch 1 closes.
3. System checks primary limit and other interlocks. Will not start if either switch is open.

Prepurge:

1. TDR1 energizes starting a 40 second prepurge cycle.
2. K4 energizes the low speed side of both blowers. If the side-wall vent option is used the power venter is energized, closing the power venter interlock. The power vent indicator light illuminates.
3. The low air indicator lights will remain lit until the blowers come up to speed. The indicator lights will turn off and prepurge indicator light will illuminate when the pressure switches make.
4. At the end of the prepurge cycle TDR1 times out and the TDR1 N.O. contacts close sending 24V ac to the ignition control.
5. The prepurge indicator light shuts off.
6. K2 will switch the pilot valve, left main valve and blower to high fire or low fire, depending on the staging.
7. K3 will switch the right main valve and blower to high fire or low fire, depending on the staging.

Ignition Trial:

1. Once energized, the flame sense module (FSM) initiates 4 second diagnostic cycle before sending 24V ac to the PV terminal and energizing the ignition transformer.
2. The flame failure LED will be lit during the 4 second diagnostic cycle unless the unit is configured for CSD-1. When the PV terminal energizes, the LED will turn off. If the ignition trial fails, the LED will relight.
3. The pilot valve and ignition transformer are energized for the 10 second ignition trial. The pilot indicator light illuminates during this time.
4. If the ignition attempt is unsuccessful, the ignition module will retry in 5 minutes.
5. Since the staging controller remains powered, it will continue to stage up for as long as the call for heat exists. The blower, pump and power venter will remain for as long as a call for heat exists.
6. If the second ignition attempt is unsuccessful the gas valves will lockout, but the blower, pump and power venter will remain on. To reset the boiler/water heater, take one of the following steps:
 - Adjust the high limit down below the point at which the blower shuts down, then reset the limit to its normal setting.
 - Remove power from the boiler/water heater, wait 30 seconds and re-establish power to the unit.

Main Burner:

1. Once the pilot is proved the MV terminal on (FSM) is energized sending 24V ac to the main gas valve.
2. The main gas valve opens via action of K1.
3. The main burner indicator light illuminates. The PV terminal remains energized and the pilot indicator remains on.

Normal Operation

- Staging will be controlled from the staging controller.
- The front control panel separately monitors limit, gas pressure, water flow and air flow.
- If staging changes during operation, blowers, pressure switches and gas valves will be switched or turned off as required.
- Stage 1 will be on first, last and whenever the boiler operates.

NOTE: For a change from stage 2 to 3 or 3 to 4, 10 second DOM time delays were added to the pressure switch switching circuits (TDR2 and TDR3). The time delays provide hold states that allow the blowers to reach full speed and close the high fire pressure switches before they are energized to confirm proper air flow.

Demand Satisfied:

1. Stage switch 1 opens, TDR1 de-energizes.
2. Power is removed from ignition module, blowers and power venter.
3. All indicators (except power) off.
4. Staging controller initiates a pump purge for 20 or more seconds, depending on the inlet/outlet temperatures and ΔT setting in the controller. The pump then shuts off.

Staging Control Alarms:

1. Staging control alarms are visible on the controller's LCD screen. See the staging control documentation for details.
2. A powered alarm contact (2A max @ 24 VAC) is available to provide an audio or visual indication of faults related only to staging control operation. This contact is wired to the junction box for optional remote indication. Refer to the 4 stage wiring diagram for tie-ins.

High Limit, Low Water Flow, Low Gas Pressure, High Gas Pressure, Power Venter Interlock Faults

1. All gas valves, the blowers and power venter will de-energize if either alarm is tripped.
2. The manual reset high limit can be reset through a knockout accessible in the left side jacket panel.
3. Condition indicators are visible on the control panel.

Low Air (Blocked Flue/Air Inlet)

- One of two pressure switches will monitor the airflow of each blower.
- Air monitoring will begin at prepurge.
- If a low air condition is present on the left side, power will not be supplied to the module. The blowers will remain on and the low air indicator will remain on for as long as a call for heat exists.
- If a low air condition is present on the right side, power will not be supplied to the right gas valve.
- A low air indicator for each boiler side is visible on the control panel.

OPERATING INSTRUCTIONS FOR YOUR SAFETY READ BEFORE OPERATING

POUR VOTRE SÉCURITÉ LISEZ AVANT DE METTRE EN MARCHÉ

- A. This appliance is equipped with an ignition device which automatically lights the pilot. Do not try to light the pilot by hand.

Cet appareil est muni d'un dispositif d'allumage qui allume automatiquement la veilleuse. Ne tentez pas d'allumer la veilleuse manuellement.

- B. BEFORE OPERATING smell all around the appliance area for gas. Be sure to smell next to the floor because some gas is heavier than air and will settle on the floor.

DANGER: Propane gas may not always be detected by smell. Propane gas is heavier than air and can collect in low areas.

Propane gas can ignite or explode if an ignition source is present and result in death, serious injury and property damage!

FOR YOUR SAFETY

- Have only qualified licensed professionals install, service and maintain this appliance and your gas system in accordance with all applicable codes.
- Install a nationally listed combustible gas detector(s) in your home.
- If you suspect a leak:
 1. Have everyone leave the building immediately.
 2. Do not attempt to light any appliance.
 3. Do not touch any electrical or electronic switches in the building.
 4. Do not use any phone in the building.
 5. Call your gas supplier from a phone outside of the building.
 6. If you cannot reach your gas supplier call the fire department.

AVANT DE FAIRE FONCTIONNER, reniflez tout autour de l'appareil pour déceler une odeur de gaz. Reniflez près du plancher, car certains gaz sont plus lourds que l'air et peuvent s'accumuler au niveau du sol.

QUE FAIRE SI VOUS SENTEZ UNE ODEUR DE GAZ:

- Ne pas tenter d'allumer d'appareil.
- Ne touchez à aucun interrupteur; ne pas vous servir des téléphones se trouvant dans le bâtiment.
- Appelez immédiatement votre fournisseur de gaz depuis un voisin. Suives les instructions du fournisseur.
- Si vous ne pouvez rejoindre le fournisseur, appelez le service de incendies.

- C. Do not use this appliance if any part has been under water. Immediately call a qualified service technician to inspect the appliance and to replace any part of the control system and any gas control that has been under water.

N'utilisez pas cet appareil s'il a été plongé dans l'eau, même partiellement. Faites inspecter l'appareil par un technicien qualifié et remplacez toute partie du système de contrôle et toute commande qui ont été plongés dans l'eau.

CAUTION: To prevent being burned, stand clear of the boiler during ignition and don't touch any hot metal parts!

Operating Instructions

1. **STOP!** Read the safety information above. If, at any time, the appliance will not operate properly, follow the instructions "TO TURN OFF GAS TO APPLIANCE".
2. Set the operating control or thermostat to off or its lowest setting.
3. Turn off all electric power to the appliance.
4. Close the main manual gas shut-off valve, Figure 16.
5. Make sure that the gas supply piping has been purged of air and that all gas joints up to the gas valve have been thoroughly checked for leaks. Wait five (5) minutes to clear out any gas. Then smell for gas, including near the floor. If you smell gas, **STOP!** Follow "B" in the safety information above (to the left) on this label. If you don't smell gas, go to the next step.
6. Remove the upper front jacket panel.
7. Turn the knob on the pilot valve to off.
8. Turn the knob on the main gas valve to off, 300 & 400 models, Figure 18. On 600 through 2100 models close the manual shutoff valve located in the control compartment, Figure 19.
9. Locate pilot and manifold pressure taps in the upper compartment. Remove the 1/8" screw plugs.
10. Connect a **20 in, 508 mm W.C.** manometer to each tapping, see Figure 19.

**Figure 18 - Pilot Valve (All Models)
Main Valve (300 & 400 Models)**

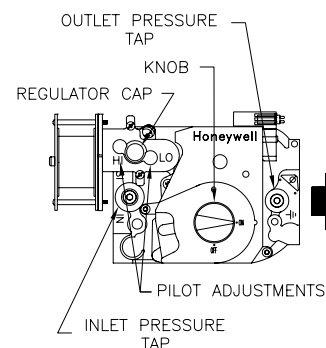

11. Turn the knob on the pilot valve to on, Figure 18.
12. Turn the knob on the main gas valve to on, 300 and 400 models, Figure 18. On 600 through 2100 models open the manual shutoff valve located in the control compartment, Figure 19.
13. Turn on all electric power to the boiler.

Figure 19 - Manual Valve & Manifold Pressure Tap

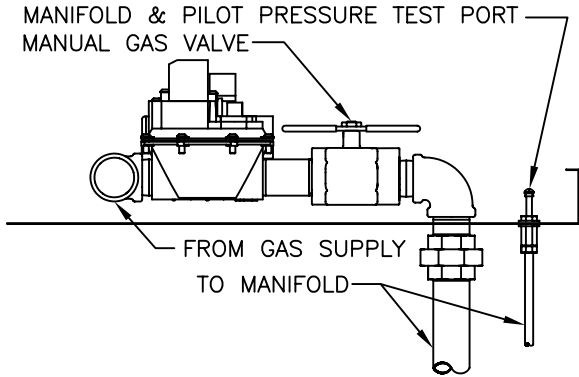

14. Set the staging control or thermostat to the desired setting.
15. The pilot should automatically light. Do not try to light the pilot by hand!
16. The burners should light with proper boiler operation.
17. The pilot and manifold pressures should match those listed in Table 19. To adjust the manifold gas pressure see the "Gas Pressure Adjustment" instructions in the "CHECKING AND ADJUSTMENTS" section.

Required Gas Pressure

Provide gas supply pressure at inlet to boiler gas train as follows:

	LP	Nat
Minimum (in W.C.)	11	6
Maximum (in W.C.)	14	14

Measure pressure when the boiler is firing at full rate. Low gas pressure could indicate undersized gas line or insufficient gas supply.

"Static and operating gas pressure required at the gas valve inlet is between 6" W.C. and 14" W.C. for natural gas and 11" W.C. and 14" W.C. for propane. If the gas pressure is above this limit, a lock-up style regulator suitable for dead end service such as an Equimeter or Fisher must be installed to prevent increase (creep) of gas pressure when the units are not operating. This pressure regulator (supplied by others) may be installed at the service entrance to each unit or a "master" regulator sized to handle multiple units may be utilized. Consult local gas utility or regulator manufacturer for recommendations to meet specific job site requirements."

Table 19 - Pilot & Manifold Settings

Natural Gas		
	inches W.C.	mm W.C.
Low Fire	1.5 ± 0.2	33 ± 5
High Fire	2.5 ± 0.2	63 ± 5
LP Gas		
	inches W.C.	mm W.C.
Low Fire	3.9 +/- 0.2	99 ± 5
High Fire	9.3 +/- 0.2	236 ± 5

Table 20 - Combustion Readings

	Natural Fuel	Propane Fuel
CO ₂ %	7.0 – 7.5 (low)	8.2 – 8.8 (low)
	7.8 – 8.5 (high)	9.2 – 9.9 (high)
O ₂ %	8.3 – 7.6 (low)	8.3 – 7.6 (low)
	7.0 – 5.8 (high)	7.0 – 5.8 (high)

Instructions De Mise En Marche

1. ARRÊTEZ! Lisez les instructions de sécurité sur la portion supérieure de cette étiquette.
2. Réglez le thermostat à la température la plus basse.
3. Coupez l'alimentation électrique de l'appareil.
4. Cet appareil est muni d'un dispositif d'allumage qui allume automatiquement la veilleuse. Ne tentez pas d'allumer la veilleuse manuellement.
5. Fermer la vanne manuelle d'arrêt d'alimentation de gaz.
6. Attendre cinq (5) minutes pour laisser échapper tout le gaz. Reniflez tout autour de l'appareil, y compris près du plancher, pour déceler une odeur de gaz. Si vous sentez une odeur de gaz, ARRÊTEZ! Passez à l'étape B des instructions de sécurité sur la portion supérieure de cette étiquette. S'il n'y a pas d'odeur de gaz, passez à l'étape suivante.
7. Ouvrir la vanne manuelle d'arrêt d'alimentation de gaz.
8. Mettez l'appareil sous tension.
9. Réglez le thermostat à la température désirée.
10. Si l'appareil ne se met pas en marche, suivez les instructions intitulées couper l'admission de gaz de l'appareil et appelez un technicien qualifié ou le fournisseur de gaz.

To Turn Off Gas To Appliance

1. Set the operating control or thermostat to its lowest setting.
2. Turn off all electric power to the appliance if service is to be performed.
3. Close the manual main valves.

COUPER L'ADMISSION DE GAZ DE L'APAREIL

1. Réglez le thermostat à la température la plus basse.
2. Coupez l'alimentation électrique de l'appareil s'il faut procéder à l'entretien.
3. Fermer la vanne manuelle d'arrêt d'alimentation de gaz.

CHECKING & ADJUSTMENTS

1. With the burners in operation, close the manual shutoff valve in the gas supply line. As soon as the main burner flames go out, open the manual shutoff valve. A normal ignition sequence should take place. If the burners fail to light, the gas valves will close and the system will go into a 5-minute lock out period. The ignition module will then make a second ignition attempt. If the unit won't light ensure that the gas piping is fully purged of air. Inspect the ignition system and ensure that it is operating properly.
2. To test the ignition safety shutoff device, close the manual shutoff valve in the gas supply line. Within 5 seconds of main burner flame extinction, the main gas valve solenoid should close with an audible noise. The pilot light on the display board should be lit while the ignition module tries to relight the pilot. After 10 seconds the module should lockout and the trial for ignition end. After 5 minutes a second trial for ignition should occur. Open the manual shutoff valve in the gas supply line and reset the ignition control system. A normal ignition sequence should take place.
3. With the burners in operation, interrupt the power to the control circuit by reducing the target temperature of the staging controller or turning down the thermostat. The boiler/water heater should stage down and shut down. Reset the operating control or thermostat. A normal ignition sequence should follow.

Input Rate, Natural Gas

Gas appliances are rated based on sea level operation with no adjustment required at elevations up to **5000 ft, 1524 m**. At elevations above **5000 ft, 1524 m**, input ratings should be reduced by 4% for each additional **1000 ft, 305 m**.

Check the input rate as follows:

1. Turn off all other gas appliances that use the same gas meter as the boiler/water heater.
2. Call your gas supplier and ask for the heating value of the gas.
3. Connect a flue gas analyzer to the vent pipe.
4. Start the boiler/water heater and let it run for 15 minutes.
5. Using the gas meter and a stopwatch, clock the time that it takes to burn **10 ft³, 0.28 m³** of gas and divide this time by 10.
6. Insert the heating value and the time, in seconds, into the formula below.
7. $\text{Input} = (\text{heating value, Btu/hr})(3600)/(\text{time, seconds})$

8. If the computed rate deviates by more than 5% from the rated input value of the unit adjust the manifold pressure accordingly. **DO NOT** adjust the manifold pressure by more than 5%. If a proper rate cannot be maintained without adjusting the manifold pressure beyond the 5% limit, the main burner orifices must be replaced. If the input rate is too low, go to the next larger size of main burner orifices. If the input rate is too high, go to the next smaller size.
9. **At full input the CO₂ should be between 7.5% and 8.5% with a CO reading of less than 50 ppm. See Table 20.**

CAUTION: Never increase the input of the boiler/water heater above that for which it is rated. Doing so can cause premature failure of the unit!

Pilot Adjustment

The pilot burner is actually an isolated main burner that stages with the other burners. It is controlled by a separate pilot valve. Pilot pressure settings are as shown in Table 19. These pressures are measured at the pilot pressure valve, see Figure 19. See Tables 12 and 13 to determine the firing mode that is associated with each stage.

To view the pilot without main burner operation, take the following steps:

For D300-D400:

1. Remove the upper front jacket panel.
2. Turn off main burner gas flow by turning the main burner gas valve knob to the off position, Figure 18.
3. Observe the pilot flame through the observation port located at the left end of the unit.

For D600-D2100:

1. Remove the upper front jacket panel.
2. Turn off main burner gas flow by turning the manual gas valve(s) in the control compartment to the off position, see Figure 19.
3. Observe the pilot flame through the observation port located at the left end of the unit.

Pilot pressures will be set at the factory. However, if it is necessary to adjust the pilot pressure to match those in Table 19, take the following steps:

1. Remove the upper front jacket panel.
2. Remove the 1/8" plug from the pilot pressure test port and connect a **20 in, 508 mm W.C.** manometer to it, see Figure 18.
3. Remove the gas pressure regulator cap from the pilot valve. See Figure 18 for the location of the regulator and cap.

4. Use a 3/32 hex wrench to turn the pressure regulator adjustment screw clockwise to increase the pilot pressure and counterclockwise to decrease it.
5. Replace the pressure regulator adjustment screw cap.

Gas Pressure Adjustment

CAUTION: The maximum inlet gas pressure listed on the rating plate must not be exceeded or damage to the boiler/water heater may occur voiding the warranty!

The minimum supply pressure listed on the rating plate is for input adjustment.

NATURAL GAS: Optimum results are obtained when the boiler/water heater is operated with the manifold pressure(s) set per Table 19. The manifold pressure should not vary outside these ranges. Each gas valve pressure regulator has been preset at the factory. If adjustment is necessary the following steps must be followed:

1. Remove the 1/8" plug(s) from the manifold pressure valves. Connect **20 in, 508 mm W.C.** manometers to them, see Figure 18.
2. Remove the regulator adjustment screw cap from the safety shut off valve(s).
3. Rotate the regulator adjustment screw clockwise to increase the manifold pressure, counterclockwise to decrease it.
4. Replace the regulator adjustment screw cap and manual shut off valve pressure tap plug.

CAUTION: Never force the regulator adjustment screw beyond the stop limits or damage to the regulator will occur!

PROPANE GAS: Optimum results are obtained when the boiler/water heater is operated with the manifold pressure(s) set per Table 19. If the manifold pressure is off by more than 5% adjust it according to steps 1 through 4 above.

Airflow Adjustment

1. Remove the upper front jacket panel.
2. Connect both sides of a manometer to the pressure switch tee, Figure 18, going to one of the pressure switches.
3. With the unit operating at high fire the differential pressure should be between **0.6 and 0.8 in, 15 and 20 mm W.C.** Do not change air pressure in lower stages.
4. To fine tune the air settings once the upper front jacket panel is installed, remove the plastic plug(s) on the upper front jacket panel. Use a Phillips screwdriver to rotate the screw(s) to obtain the CO₂ and CO readings in the INPUT RATE section above.

CONTROL DESCRIPTION

Boiler Thermostat

If a thermostat is to be used to control the boiler always follow the instructions included with the thermostat. Proper location of the thermostat will ensure efficient trouble-free operation of the boiler. Mount the thermostat to an inside wall at a height approximately five feet above the floor.

Avoid placing the thermostat in areas that will not provide an accurate measurement of the room temperature. Locating the thermostat behind a door, in an alcove, close to a source of thermal radiation or in a drafty area will cause poor or sporadic heating.

For a thermostat that employs an adjustable heat anticipator, adjust the anticipator to match the current measured in the thermostat circuit. An increased anticipator setting may be necessary if the unit cycles frequently. If the room temperature over-shoots the thermostat setting, reduce the anticipator setting.

Operating Control

The preferred control setting for potable hot water is **130°F, 54°C**. The operating control should be set to the lowest setting that will satisfy the consumer's needs.

WARNING: Setting the thermostat or operation control too high can result in scalding resulting in severe personal injury!

High Limit (Aquatat)

The high limit is located in the left side area of the boiler/water heater. A remote capillary bulb is run to a well on the outlet side of the supply header. The high limit can be reset by depressing the black rubber plug in the front top jacket panel.

The water heater high limit should be set a minimum of **20°F, 11°C** higher than the operating control. Refer to the HOT WATER SUPPLY section for the proper supply water temperature.

Flow Switch

A flow switch is provided in the water outlet piping to prevent the boiler/water heater from firing without adequate water flow through the heat exchanger.

Low Water Cutoff

If the boiler is to be installed above radiation or if required by other codes or regulations, install a low water cutoff in appropriate piping. Wire the switch and any external controls in series to the "Interlock" contacts in the junction box (see the attached Connection Diagrams for details). Ensure that the low water cutoff device(s) will function properly.

Flame Sense Module

The flame sense module is located on the control tray. It is an intermittent pilot control device that controls the pilot gas flow, spark energy to ignite the pilot gas and the main valve(s) once pilot ignition has been proven.

Two flame failure alarm terminals are provided on the flame sense module. For CSD-1, these terminals will be utilized to shut the unit down in case of flame failure. The two terminals will be connected to a lockout control module located on the control tray under the flame sense module. This lockout control module contains a magnetic latch relay that requires manual reset when de-energized. To reset after flame failure, push and release the momentary contact switch located within the front control panel.

Relay Board

The relay board is located in the control tray. It provides sequencing of the gas valves and blower(s) based on the staging controller's input. It also provides the following time delays for proper unit operation:

- A 40 second prepurge when stage 1 is energized.
- A 10 second pressure switch sequencing delay when the blowers switch from low fire to high fire.
The delay enables the blower to come up to speed before the high pressure side of the pressure switch confirms proper air flow.

These time delays are set within the separate time delay board connected to the relay board.

Gas Pressure Switch

An optional low and/or high gas pressure switch will shut down the 24V circuit if excessively high or low gas pressure exists in the gas train or supply piping.

BTC Staging Control

The staging control is located at the front of the control tray. It utilizes various temperature sensors to calculate boiler/water heater demand and adjust the stages as required. Various features of the control can be adjusted from the 3-button panel on the controller. To change settings of the staging controller, press and hold all three buttons approximately 2 seconds until the "adjust" screen appears, then release them. The staging controller provides 6 modes of operation based on the requirements of the system. The desired mode can be set manually from the controller. Each mode is defined below. Refer to the control manufacturer's documentation for more information on the controller and its adjustment features.

At the rear of the controller, two DIP switches are provided to allow an installer to modify staging control operation. These switches are factory set to provide a "lockout" with minimum adjustment capabilities in the field. However, for experienced installers and operators, changing these switch settings can offer many fine-tuning features. Consult the control manufacturer's documentation for more information on the controller and its adjustment features.

CAUTION: DO NOT change DIP switch or controller settings unless you have completely read and understood this document and the control manufacturer's instructions. Doing otherwise will lead to improper stage control operation.

Mode 1: Setpoint control. Dominator piped in parallel with the system. The firing stages are operated to provide a setpoint temperature at the boiler/water heater outlet.

SETPOINT OPERATION - The control operates the boiler stages to maintain the programmed temperature at the boiler/water heater outlet sensor whenever a heat demand is present.

Mode 2: Setpoint control. Dominator piped in primary/secondary configuration. An additional system sensor is required to properly control the system supply (primary loop) temperature. The firing stages are operated to provide a setpoint temperature in the primary loop.

SETPOINT OPERATION - The control operates the boiler/water heater stages to maintain the programmed temperature at the supply sensor (primary loop sensor) whenever a heat demand is present.

Mode 3: Domestic Hot Water (DHW) generation.

Dominator piped in parallel with the storage tank. DHW demand from sensor located in tank or pool supply pipe. The firing stages are operated to provide a setpoint temperature and maintain DHW tank temperature.

DHW OPERATION - The control operates to maintain the programmed tank target temperature at the outlet sensor whenever a DHW demand is present. A DHW demand is generated whenever the temperature sensed by the DHW sensor drops below the programmed tank target temperature by 1/2 the programmed differential, adjustable from **2 to 10°F**, **-17 to -12°C**. The demand remains until the temperature sensed by the DHW sensor rises above the programmed tank target temperature plus 1/2 the programmed differential.

Mode 4: Outdoor reset control. Dominator piped in parallel with the system. The firing stages are operated to provide outdoor reset temperature control at the boiler/water heater outlet.

OUTDOOR RESET OPERATION - The control operates the water heater/boiler stages to maintain the calculated target supply temperature at the boiler outlet sensor. The temperature is calculated by the outdoor reset feature, which increases the target boiler outlet temperature as outdoor temperature drops. Whenever the outdoor temperature is greater than the WWSD (Warm Weather Shut Down) setting, the control ignores the call for heat.

OUTDOOR RESET WITH DHW OPERATION - A DHW tank controlled by a pump provides reset override whenever DHW generation is required. In Mode 4, reset override will occur if the staging controller receives a signal across the "STPT DEM" and "DEM SIG" terminals of the terminal strip. (i.e., closing a tank aquastat switch wired to these terminals). In this case, the control will temporarily override outdoor reset and increase the target temperature to **180°F**, **82°C** to provide sufficient heat to satisfy the DHW requirement.

Mode 5: Outdoor reset control. Dominator piped in primary/secondary configuration. An additional system sensor is required to properly control the system supply (primary loop) temperature. The firing stages are operated to provide outdoor reset temperature control in the primary loop.

OUTDOOR RESET OPERATION - The control operates the water heater/boiler stages to maintain the calculated target supply temperature at the supply sensor. The temperature is calculated by the outdoor reset feature, which increases the target supply temperature as outdoor temperature drops. Whenever the outdoor temperature is greater than the WWSD (Warm Weather Shut Down) setting, the control ignores the call for heat.

OUTDOOR RESET WITH DHW OPERATION - A DHW tank controlled by a pump provides reset override whenever DHW generation is required. In Mode 5, reset override will occur if the staging controller receives a signal across the "STPT DEM" and "DEM SIG" terminals of the terminal strip. (i.e., closing a tank aquastat switch wired to these terminals). In this case, the control will temporarily override outdoor reset and increase the target temperature to **180°F**, **82°C** to provide sufficient heat to satisfy the DHW requirement.

Mode 6: Multiple BTC controls. The control only operates the pump and stage one.

REMOTE STAGING - An external staging control is used to control and stage multiple boiler/water heaters. Factory supplied terminals in the electrical box are used.

The operating control on the boiler/water heater is set to its lowest setting when the water heater leaves the factory. The preferred control setting for potable hot water is **130°F**, **54°C**. The operating control should be set to the lowest setting that will satisfy the consumer's needs.

MAINTENANCE

WARNING: Disconnect electrical power and close the manual gas shut off valve before performing maintenance or severe personal injury may result!

WARNING: Improper installation, adjustment, alteration, service or maintenance can cause property damage, personal injury, exposure to hazardous materials or loss of life. Installation and service must be performed by a qualified installer, service agency or the gas supplier who must read and follow the supplied instructions before installing, servicing or removing this boiler. This boiler contains crystalline silica materials that have been identified as carcinogenic or possibly carcinogenic to humans when inhaled.

AVERTISSEMENT: une installation, un réglage, une réparation ou un entretien non conforme aux normes peut entraîner des dommages matériels, des blessures, exposition à des matières dangereuses ou la mort. L'installation et l'entretien doivent être effectués par un installateur ou un service d'entretien qualifié ou le fournisseur de gaz qui doivent avoir lu les instructions fournies avant de faire l'installation, l'entretien ou l'enlèvement de la chaudière et les respecter, Cette chaudière contient des matériaux qui ont été identifiés comme étant cancérigènes ou pouvant l'être.

CAUTION: Servicing, inspection and adjustment must be done by a trained technician in accordance with all applicable local and national codes. Improper servicing or adjustment can damage the boiler/water heater!

WARNING: The ceramic combustion chamber contains crystalline silica. Wear a tightly fitted dust mask when removing the burners or heat exchanger to prevent inhalation of airborne fibers. Crystalline silica fibers have been identified as carcinogenic, or possibly carcinogenic when inhaled.

The boiler/water heater should be cleaned and inspected once a year, before each heating season. Make sure that the burner and ignition components are free from dust, soot, dirt, corrosion or other deposits that would impair the boiler/water heater's performance. Refer to page 39 for component identification.

CAUTION: Improper burner servicing can result in premature burner failure voiding the warranty!

Burner Inspection And Removal - Figure 20

1. Close the manual shutoff valves in the gas supply lines and turn off electrical power to the boiler/water heater.
2. Remove the jacket front panels.
3. Disconnect the manifold gas piping at the ground joint union(s). Also disconnect the pressure sensing lines, pilot tubing and ignition and sensing leads.
4. Remove the manifold(s).
5. Remove the burner(s) from the lower front combustion chamber panel.
6. Inspect the burner(s) for damage or signs of deterioration. Use a brush or compressed air to remove any debris from the burner ports.
7. DO NOT install a damaged or badly corroded burner, replace it.
8. Install the burner(s) making sure that the burner gasket is not torn or deteriorated. If it is replace it.
9. Reassemble the unit following the removal steps in reverse order.

Heat Exchanger Inspection - Figure 20

1. Close the manual shutoff valves in the gas supply lines and turn off electrical power to the boiler/water heater.
2. Remove the jacket front panels.
3. Disconnect gas piping at the ground joint union(s). Also disconnect the pressure sensing lines, pilot tubing and ignition and sensing leads.
4. Remove the upper partition panel, 1050 thru 2100 models.
5. Remove the 1/4 inch nuts and washers holding the upper combustion chamber front panel in place and carefully remove it.
6. Inspect the inside and outside of the heat exchanger for signs of damage, sooting or corrosion.
7. The outside surfaces of the copper tubes should be free of any soot deposits. A slight black smudge is normal with some types of gases. Black soot indicates poor combustion. Green deposits indicate condensation due to low return water temperatures. In either case the heat exchanger must be cleaned thoroughly and the problem resolved before the boiler/water heater is returned to service.
8. If there are no signs of damage, sooting or corrosion reassemble the unit following the previous steps in reverse order.
9. A badly corroded or damaged heat exchanger must be replaced, see the **Heat Exchanger Removal** section.

Heat Exchanger Removal, Cleaning & Replacement - See Figure 20

1. Close the shut off valves in the inlet and outlet piping. On heating systems close the system fill valve and relieve the system pressure from the boiler by carefully lifting the relief valve or opening the drain valve.
 2. Drain the boiler/water heater and disconnect it from the system piping.
 3. Remove the inlet/outlet and return headers.
 4. Remove the front jacket panels.
 5. Loosen, 4 turns, but **don't remove** the 6 screws (3 on each side) holding the heat exchanger upper rails in place, Figure 21.
 6. Disconnect gas piping at the ground joint union(s). Also disconnect the pressure sensing lines, pilot tubing and ignition and sensing leads.
 7. Remove the upper partition panel, 1050 thru 2100 models.
 8. Remove the 1/4 inch nuts and washers holding the upper combustion chamber front panel in place and carefully remove it.
 9. Carefully slide the heat exchanger out of the unit.
 10. Remove the "V" baffle straps and "V" baffles.
 11. Thoroughly inspect the heat exchanger for signs of damage. If there is no damage, clean the heat exchanger with water from a high-pressure hose. Use a soft bristle brush if necessary.
- CAUTION: Never clean the heat exchanger while it's in the boiler/water heater or the combustion chamber will be destroyed!**
12. Sagging or distorted heat exchanger tubes are an indication of low water flow through the system. A leaking or otherwise damaged heat exchanger must be replaced and the condition that caused the damage resolved before the boiler/water heater is returned to service.
 13. If the heat exchanger isn't damaged rewire the heat exchanger baffles in place and slide the heat exchanger back into the unit.
 14. Reinstall all of the other components in the reverse order of their removal.

Figure 20 - Burner and Heat Exchanger Servicing

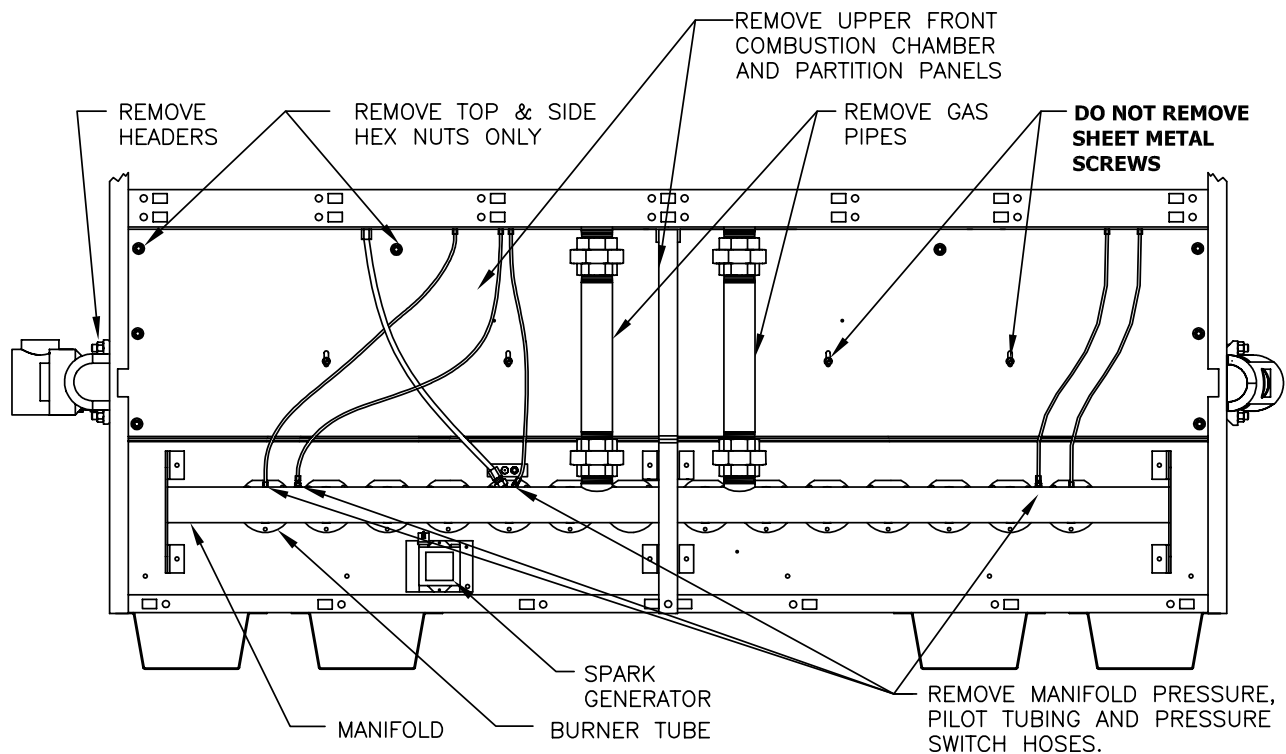
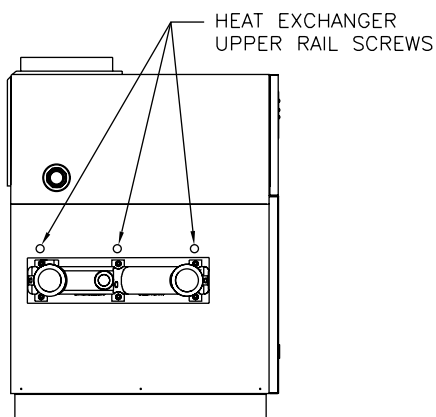

Figure 21 - Heat Exchanger Upper Rail Screws**Vent System**

Thoroughly inspect the vent system for any signs of blockage, corrosion or leakage. Immediately replace any unsound vent system piping.

Controls

Use the "BOILER/WATER HEATER OPERATION" and "CHECKING AND ADJUSTMENTS" sections of this manual for reference.

1. Check the thermostat or operating controls for proper operation.
2. A float type low water cutoff device must be flushed out per the manufacturers' instructions. The probe on a probe low water cut off must be removed, cleaned and inspected at least once a year. Ensure that the low water cutoffs operate properly. If not, replace them.
3. The flow switch contacts must be open when water flow is not present.
4. The relief valve should not weep or discharge water at normal system pressure. If it does, contact a qualified service technician to have it inspected. NEVER try to clean or repair the relief valve! If the valve fails to operate properly, have it replaced!

5. The aquastat high limit controls the maximum water temperature in the boiler. It should be set at least **20°F, 11°C** above the operator setpoint. If the water temperature reaches the set temperature before the demand for heat has been met, the aquastat high limit should shut the boiler off. The water temperature should never exceed the maximum set point of **240°F, 116 °C**. The aquastat high limit cannot be repaired. If it fails to function properly replace it.
6. Visually check the pilot and main burner flames to ensure proper operation, see Figure 22.

WARNING: A yellow, floating flame indicates a lack of combustion air. A lifting flame indicates too much combustion air. Do not operate the boiler/water heater until the problem is solved or severe personal injury or death may occur!

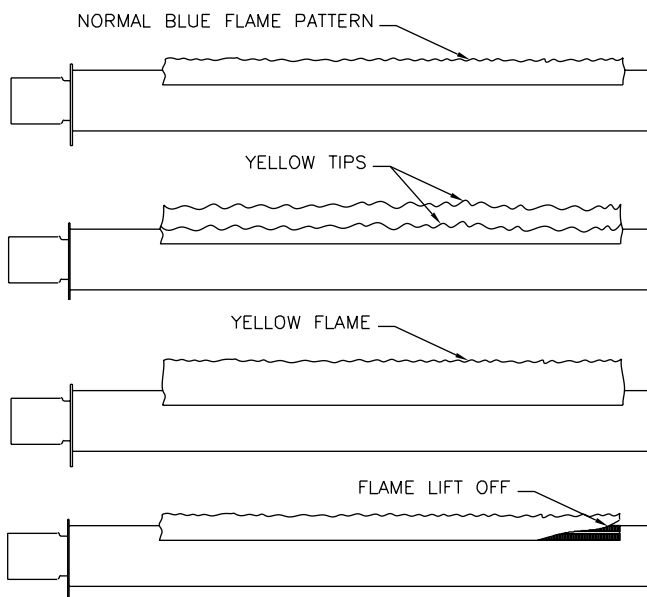
Figure 22 - Pilot & Main Burner Flame

Trouble-Shooting

PROBLEM	POSSIBLE CAUSES	CORRECTIVE ACTION
No Power To Unit	Power not connected	Wire unit to line voltage
	External circuit breaker open	Reset breaker
	Relay board fuse (24V) blown	Replace fuse
	Transformer circuit breaker open (4 stage)	Reset breaker
No Action On Call For Heat	Primary limit or other control/interlock open	<ul style="list-style-type: none"> • Check indicator board, reset limit or control or resolve problem as applicable • If not resolved, check wiring and condition of limit.
	Low water cutoff open	<ul style="list-style-type: none"> • Check circulating pump • Check pump contact in J-box • Check LWCO wiring and condition
	Stage control sensor(s) not wired or are malfunctioning	<ul style="list-style-type: none"> • Wire sensor(s) to J-box or replace as necessary • Check error message on control, refer to control documentation
	Stage control malfunction	Replace stage control
No Power To Pump	Pump contact not wired	Wire pump contact to J-box
	Stage control malfunctioning	Replace stage control
	Pump malfunctioning	Replace pump
No Power to Power Venter	Power venter contact not wired	Wire power venter contact to J-box
	Power venter not wired to external power	Wire power venter as shown in connection diagram
	Relay fault	Replace relay
	Power venter fault	Replace power venter
Power Venter On, No Action From Unit	Power venter interlock open	<ul style="list-style-type: none"> • Check indicator board for power vent indication • If indication exists, check flue or chimney for blockage
	Power venter interlock not wired	Wire power venter interlock as shown in connection diagram
No Power To Blower(s)	Blower(s) not plugged in	Plug in blower(s)
	Relay fault	Replace blower relay
	Blower(s) malfunctioning	Replace blower(s)
	Fault in prepurge circuit	Replace timer board
Unit Does Not Spark	Incorrect spark gap or shorted ignitor lead	Adjust ignitor rod or correct short
	Bad ground on flame sense module	Check ground connections, adjust as necessary
	Low air (blocked flue/inlet) condition	<ul style="list-style-type: none"> • Check indicator board for low air indication • If condition exists, check inlet, flue, chimney for blockage • Check combustion air/ventilation openings in space • Check inlet air filter, clean/replace as necessary

Trouble-Shooting

PROBLEM	POSSIBLE CAUSES	CORRECTIVE ACTION
Unit Does Not Spark <i>continued</i>	Spark generator fault	• Check spark generator wiring
Unit Sparks But Will Not Fire	Low gas pressure	Check gas supply pressure, adjust as necessary
	Pilot valve manual knob closed	Open pilot valve manual knob
	Pilot wires disconnected	Reconnect wires
	Low pilot pressure	Check pilot pressure, adjust as necessary
	Pilot valve malfunctioning	Replace pilot valve
Pilot Lights But Unit Will Not Fire	Bad flame sense lead from ignitor to flame sense module	Check ground connections, adjust as necessary
	Manual valve(s) closed	Remove upper front jacket panel, open manual valve(s)
	Low manifold pressure	Check manifold pressure, adjust as necessary
	Main valve(s) malfunctioning	Replace main valve(s)
Insufficient Heating	Target temperature too low	Increase stage control target temperature
	Primary (safety high) limit set too low	Increase limit setting
Unit Consistently Shuts Down On Limit	Primary (safety high) limit set too low	Increase limit setting
Bad Combustion (High CO, Yellow Flames)	Insufficient air	<ul style="list-style-type: none"> • Check CO, adjust blower inlet damper(s) to increase airflow • Check for plenum air leakage from lower front jacket panel seams, repair as necessary
	Dirty inlet air filter	Remove, inspect and clean inlet air filter as necessary
	Too much air	Check CO, adjust blower inlet damper(s) to decrease airflow
Gas Flow Shuts Down During Operation (Blowers Remain On)	Low air (blocked flue/inlet) condition	<ul style="list-style-type: none"> • Check indicator board for low air indication • If condition exists, check inlet, flue, chimney for blockage • Check combustion air/ventilation openings in space • Check inlet air filter, clean/replace as necessary

Figure 28 - Replacement Parts

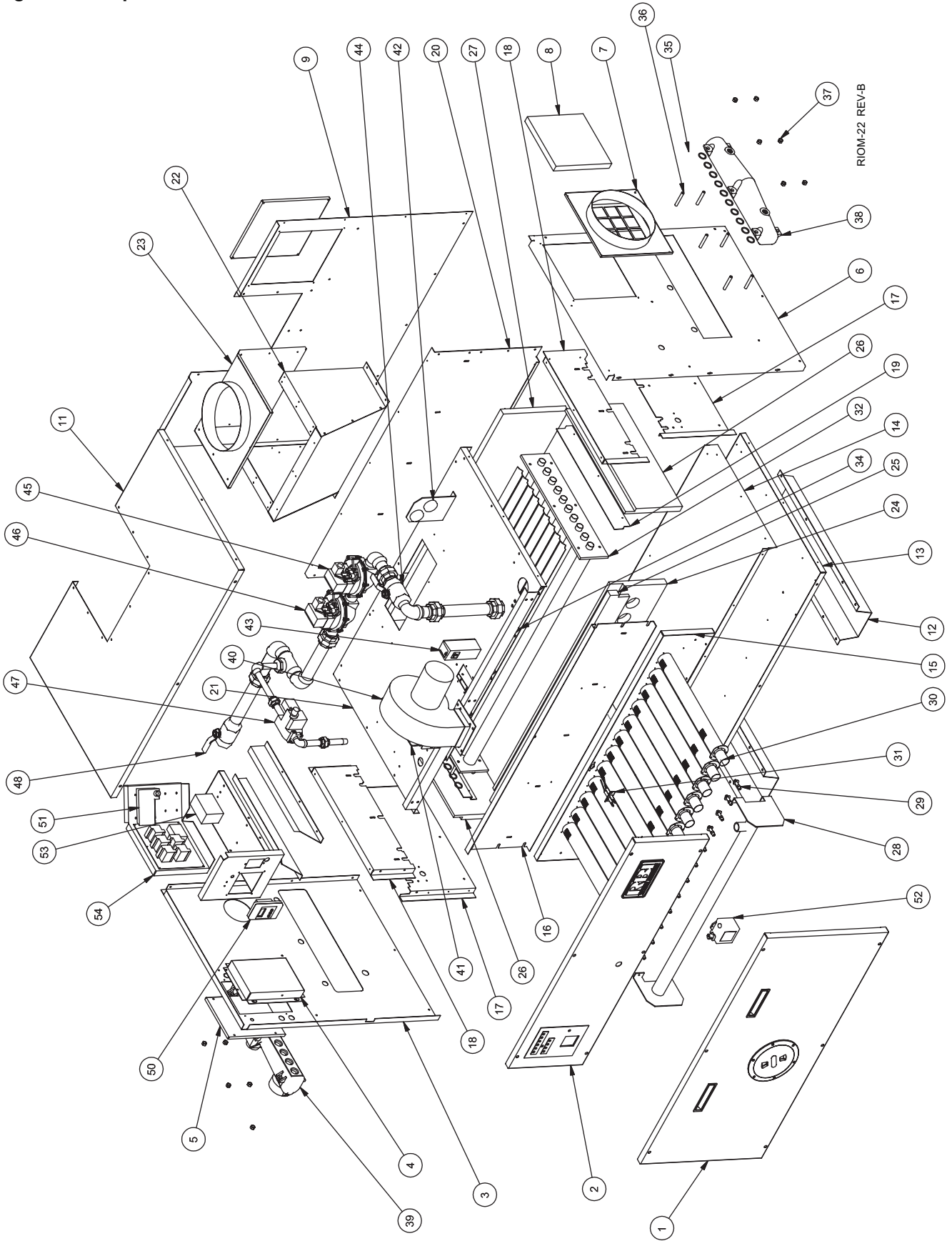

SERVICE AND REPLACEMENT PARTS LIST (MODELS 300-2100)

Ref #	Name of Part	Part #	300	400	600	750	900	1050	1350	1500	1950	2100	
1	Jacket Lower Front Panel	70-2716	1										
		70-2717		1									
		70-2718			1								
		70-2719				1							
		70-2720					1						
		70-2721						1					
		70-2722							1				
		70-2723								1			
		70-2724									1		
	70-2725										1		
	Jacket Lower Front Panel (SS)	70-2716.1	1										
		70-2717.1		1									
		70-2718.1			1								
		70-2719.1				1							
		70-2720.1					1						
		70-2721.1						1					
		70-2722.1							1				
		70-2723.1								1			
	70-2724.1									1			
	70-2725.1											1	
	Handle	20-0050	1	1	1	1	1	2	2	2	2	2	
Deckplate	20-0062				1	1	1	1	1	1	1		
2	Jacket Upper Front Panel	70-2706	1										
		70-2707		1									
		70-2708			1								
		70-2709				1							
		70-2710					1						
		70-2711						1					
		70-2712							1				
		70-2713								1			
		70-2714									1		
	70-2715										1		
	Jacket Upper Front Panel (SS)	70-2706.1	1										
		70-2707.1		1									
		70-2708.1			1								
		70-2709.1				1							
		70-2710.1					1						
70-2711.1							1						
70-2712.1							1						
70-2713.1								1					
70-2714.1									1				
70-2715.1											1		
3	Jacket Left Side Panel	03-1822	1	1	1	1	1	1	1	1	1	1	
	Jacket Left Side Panel (SS)	03-1822.1	1	1	1	1	1	1	1	1	1	1	
4	Junction Box Assembly	70-2814	1	1	1	1	1	1	1	1	1	1	
5	Junction Box Cover	03-2036	1	1	1	1	1	1	1	1	1	1	
6	Jacket Right Panel	03-1823	1	1	1	1							
		03-1825					1	1	1	1	1	1	
	Jacket Right Panel (SS)	03-1823.1	1	1	1	1							
		03-1825.1					1	1	1	1	1		
7	Combustion Air Inlet Assembly (Indoor)	70-2744	1	1									
		70-2746			1	1							
		70-2748					1	1					
		70-2749							1	1	1	1	
	Combustion Air Inlet Assembly (Outdoor)	70-2820	1	1									
		70-2821			1	1							
		70-2822					1	1					
		70-2823						1	1	1	1		
8	Filter (Indoor)	09-0488	1	1									
		09-0489			1	1							
		09-0497					1	1					
		09-0498							1	1	1	1	
	Filter (Outdoor)	09-0490	1	1	1	1							
		09-0491					1	1	1	1	1	1	



START UP FORM

Date of Start Up: _____ **Job Name:** _____
Model #: _____ **Serial Number #:** _____
Boiler Model: Dominator **Company Name** _____
Fuel Type: Natural Gas Propane **Tech Name** _____
System Type: Hydronic Domestic **Phone Number** _____

PRE-START UP CHECK LIST

- | | |
|---|--|
| <input type="checkbox"/> ANY VISUAL DAMAGE TO UNIT? | <input type="checkbox"/> INLET FILTER INSTALLED AND CLEAN? |
| <input type="checkbox"/> PIPING PROPERLY CONNECTED? | <input type="checkbox"/> ALL WIRING CONNECTED PROPERLY? |
| <input type="checkbox"/> SYSTEM FLOODED AND FLOWING? | <input type="checkbox"/> BOILER PUMP PUMPING INTO INLET? |
| <input type="checkbox"/> BOILER CIRCULATOR WIRED? | <input type="checkbox"/> COMBUSTION AIR PROVIDED? |
| <input type="checkbox"/> VENT/STACK CONNECTED? | <input type="checkbox"/> PROPER SERVICE CLEARANCE PROVIDED? |
| <input type="checkbox"/> IS VENT VERTICAL THROUGH THE ROOF? | <input type="checkbox"/> OUTDOOR AIR SENSOR INSTALLED/WIRED? |
| <input type="checkbox"/> IS VENT THROUGH THE WALL? | <input type="checkbox"/> ARE UNITS RACKED? |
| <input type="checkbox"/> IS POWER VENT INSTALLED AND WIRED? | <input type="checkbox"/> IS RACK ASSEMBLED TIGHTLY? |
| <input type="checkbox"/> SEALED COMBUSTION? | <input type="checkbox"/> NO HOLES SCREWED INTO CABINET? |

ELECTRICAL/WIRING/CONTROL

_____ Boiler Supply Voltage _____ External BMS System
 _____ Boiler Pump Supply Voltage _____ Utilize Boiler BTC For Control
 _____ Voltage Down Stream of Transformer

BTC CONTROL SET UP:

<input type="text"/> : Mode	_____ : Boiler Max	_____ : Purge ΔT
_____ : Boiler Target	_____ : Boiler Min	
_____ : Tank Target	_____ : Boiler Diff	
_____ : Tank Diff	_____ : Intr-Stg Diff	
_____ : Outdoor Start	_____ : Intr-Stg On Dly	
_____ : Boiler Start	_____ : Intr-Stg Off Dly	

COMBUSTION/SAFETY REPORT

FACTORY FIRE TEST REPORT:	Low Fire	High Fire	These results are affixed to the side of the heater on a small white label.
Manifold Gas Pressure: "W.C.			
Air Differential Pressure: "W.C.			

FIELD TEST REPORT IN STAGE:	1	2	3	4
Manifold Gas Pressure: "W.C.				
Air Differential Pressure: "W.C.				
Pilot Manifold Pressure: "W.C.				
CO ₂ :				
Stack Temp. (Net):				
Efficiency @ _____ °F Inlet Temp.				
CO (PPM):				
Stack Draft (Must Be Negative):				
Pilot Signal:				

SAFETY CONTROL CHECK:	Wired and Operating Properly @ Setting:	Failed To Operate Comment To Right	Comments
Low Water Cut Off (PPM):			
Factory Flow Switch			
Operating Control			
High Limit			
Differential Air Switch STG. 1, 2			
Differential Air Switch STG. 3, 4			
Blocked Flu Switch			
Flame Failure Lockout (CSD-1)			
Pump Delay			
Combustion Air Damper			
Power Vent Proving Switch			
Barometric Damper			

NOTICE!

Commonwealth of Massachusetts Installation Requirements

MACODE-3

NOTICE In the Commonwealth of Massachusetts, the installation must be performed by a licensed plumber or gas fitter.

1. For all side wall horizontally vented gas fueled equipment installed in every dwelling, building or structure used in whole or in part for residential purposes, including those owned or operated by the commonwealth and where the side wall exhaust vent termination is less than seven (7) feet above finished grade, in the area of the venting, including but not limited to decks and porches, the following requirements shall be satisfied:

d. INSTALLATION OF CARBON MONOXIDE DETECTORS.

At the time of installation of the side wall horizontal vented gas fueled equipment, the installing plumber or gasfitter shall observe that a hard wired carbon monoxide detector with an alarm and battery back-up is installed on the floor level where the gas equipment is to be installed. In addition, the installing plumber or gasfitter shall observe that a battery operated or hard wired carbon monoxide detector with an alarm is installed on each additional level of the dwelling, building or structure served by the side wall horizontal vented gas fueled equipment. It shall be the responsibility of the property owner to secure the services of qualified licensed professionals for the installation of hard wired carbon monoxide detectors.

- i. In the event that the side wall horizontally vented gas fueled equipment is installed in a crawl space or an attic, the hard wired carbon monoxide detector with alarm and battery back-up may be installed on the next adjacent floor level.
 - ii. In the event that the requirements of this subdivision can not be met at the time of completion of installation, the owner shall have a period of thirty (30) days to comply with the above requirements; provided, however, that during said thirty (30) day period, a battery operated carbon monoxide detector with an alarm shall be installed.
- e. APPROVED CARBON MONOXIDE DETECTORS.** Each carbon monoxide detector as required in accordance with the above provisions shall comply with NFPA 720 and be ANSI/UL 2034 listed and IAS certified.
- f. SIGNAGE.** A metal or plastic identification plate shall be permanently mounted to the exterior of the building at a minimum height of eight (8) feet above grade directly in line with the exhaust vent terminal for the horizontally vented gas fueled heating appliance or equipment. The sign shall read, in print size no less than one-half (1/2) inch in size, "GAS VENT DIRECTLY BELOW. KEEP CLEAR OF ALL OBSTRUCTIONS".
- g. INSPECTION.** The state or local gas inspector of the side wall horizontally vented gas fueled equipment shall not approve the installation unless, upon inspection, the inspector observes carbon monoxide detectors and signage installed in accordance with the provisions of 248 CMR 5.08(2)(a)1 through 4.

WARNING Improper venting can result in excessive levels of carbon monoxide which can cause severe personal injury or death!

2. Exemptions — The following equipment is exempt from 248 CMR 5.08(2)(a) 1 through 4:
 - a. The equipment listed in Chapter 10 entitled "Equipment Not Required To Be Vented" in the most current edition of NFPA 54 as adopted by the Board; and
 - b. Product Approved side wall horizontally vented gas fueled equipment installed in a room or structure separate from the dwelling, building or structure used in whole or in part for residential purposes.
3. MANUFACTURER REQUIREMENTS - GAS EQUIPMENT VENTING SYSTEM PROVIDED.
 - a. When the manufacturer of Product Approved side wall horizontally vented gas equipment provides a venting system design or venting system components with the equipment, the instructions provided by the manufacturer for installation of the equipment and the venting system shall include:
 - i. Detailed instructions for the installation of the venting system design or the venting system components; and
 - ii. A complete parts list for the venting system design or venting system.
4. MANUFACTURER REQUIREMENTS – GAS EQUIPMENT VENTING SYSTEM NOT PROVIDED.
 - a. When the manufacturer of a Product Approved side wall horizontally vented gas fueled equipment does not provide the parts for venting the flue gases, but identifies "special venting systems", the following requirements shall be satisfied by the manufacturer:
 - i. The referenced "special venting system" instructions shall be included with the appliance or equipment installation instructions; and
 - ii. The "special venting systems" shall be Product Approved by the Board, and the instructions for that system shall include a parts list and detailed installation instructions.
5. A copy of all installation instructions for all Product Approved side wall horizontally vented gas fueled equipment, all venting instructions, all parts lists for venting instructions, and/or all venting design instructions shall remain with the appliance or equipment at the completion of the installation.

WARNING Improper venting can result in excessive levels of carbon monoxide which can cause severe personal injury or death!

LIMITED WARRANTY

Boilers/Water Heaters Industrial, Commercial and Other Non-Residential Use

The "Manufacturer" warrants to the original owner at the original installation site that the heat exchanger of the Industrial, Commercial, and other Non-Residential Use Boiler (the "Product") will be free from defects in material or workmanship for ten (10) years from the date of installation. Additional twenty one (21) year thermal shock warranty on heat exchanger. If upon examination by the Manufacturer the Product is shown to have a defect in material or workmanship during the warranty period, the Manufacturer will repair or replace, at its option, that part of the Product which is shown to be defective. All other RBI supplied Boiler/Water Heater parts are warranted against defects in material and workmanship for one (1) year from date of installation or 18 months from date of shipment from RBI.

The "Manufacturer" warrants to the original owner at the original installation site that the heat exchanger of the Industrial, Commercial, and other Non-Residential Use Water Heater (the "Product") will be free from defects in material or workmanship for five (5) years from the date of installation. Additional twenty one (21) year thermal warranty on heat exchanger. If upon examination by the Manufacturer the Product is shown to have a defect in material or workmanship during the warranty period, the Manufacturer will repair or replace, at its option, that part of the Product which is shown to be defective. All other RBI supplied Boiler/Water Heater parts are warranted against defects in material and workmanship for one (1) year from date of installation or 18 months from date of shipment from RBI.

This limited warranty does not apply:

- (a) if the Product has been subjected to misuse or neglect, has been accidentally or intentionally damaged, has not been installed, maintained or operated in accordance with the furnished written instructions, or has been altered or modified in any way.

These include but not limited to:

- Excessive water hardness causing a lime build-up in the heat exchanger tubes is not a fault of the equipment and is not covered under the manufacturer's warranty.
- Excessive pitting and erosion on the inside of the heat exchanger tubes caused by high water velocity through the tubes and is not covered by the manufacturer's warranty. (See Installation Instructions for proper pump performance.)
- Chemical corrosion, no corrosive chemical (freon, dry cleaning chemicals, degreasing liquids, chlorine or any chemicals that produce hydrochloric acid) can be present in the boiler room as it rapidly destroys the heating equipment and voids the warranty.
- All copper fin boilers should not operate with a return water temperature less than 110°F, 43°C atmospheric combustion, 125°F, 52°C fan assist combustion. If a lower temperature is required, an external bypass should be installed to prevent condensation. The manufacturer's warranty does not cover damage done by condensation.

- (b) to any expenses, including labor or material, incurred during removal or reinstallation of the Product or parts thereof.
- (c) to damage as a result of settlement, distortion, collapse, or cracking of any foundation area, beams or pipes surrounding the Product.
- (d) to any workmanship of any installer of the Product; or to Products installed outside the continental United States or Canada.

This limited warranty is conditional upon:

- (a) shipment, to the Manufacturer, of that part of the Product thought to be defective. Goods can only be returned with prior written approval from the Manufacturer. All returns must be freight prepaid.
- (b) determination in the reasonable opinion of the Manufacturer that there exists a defect in material or workmanship.

Repair or replacement of any part under this Limited Warranty shall not extend the duration of the warranty with respect to such repaired or replaced part beyond the stated warranty period.

THIS LIMITED WARRANTY IS IN LIEU OF ALL OTHER WARRANTIES, EITHER EXPRESS OR IMPLIED, AND ALL SUCH OTHER WARRANTIES, INCLUDING WITHOUT LIMITATION IMPLIED WARRANTIES OF MERCHANTABILITY OR FITNESS FOR A PARTICULAR PURPOSE, ARE HEREBY DISCLAIMED AND EXCLUDED FROM THIS LIMITED WARRANTY. IN NO EVENT SHALL THE MANUFACTURER BE LIABLE IN ANY WAY FOR ANY CONSEQUENTIAL, SPECIAL, OR INCIDENTAL DAMAGES OF ANY NATURE WHATSOEVER, OR FOR ANY AMOUNTS IN EXCESS OF THE SELLING PRICE OF THE PRODUCT OR ANY PARTS THEREOF FOUND TO BE DEFECTIVE. THIS LIMITED WARRANTY GIVES THE ORIGINAL OWNER OF THE PRODUCT SPECIFIC LEGAL RIGHTS. YOU MAY ALSO HAVE OTHER RIGHTS WHICH MAY VARY BY EACH JURISDICTION.



260 North Elm Street
Westfield, MA 01085
Phone: (413) 568-9571
Fax: (413) 568-9613

■ 7555 Tranmere Drive
Mississauga, Ontario L5S 1L4 Canada
Phone: (905) 670-5888
Fax: (905) 670-5782

